

KATALOG / CATALOGUE 2023

 ***kalitegaz***

3innova

RODO

SINCE 1977

HAKKIMIZDA

Firmamız 1977 yılında İstanbul'da endüstriyel mutfak cihazları imalatına başlayarak sektördeki yerini almıştır. Firmamız kurulduğu günden itibaren kaliteyi, müşteri memnuniyetini ve sürekli teknolojik gelişmeyi kendine vizyon edinmiştir. Müşterilerinin beklenti ve talepleri doğrultusunda ürünlerini çeşitlilik, fonksiyonellik, pişirme performansı ve apre gibi özellikler açısından sürekli geliştirmeyi hedefler. Kataloğumuzda bulunan tüm ürünler CE sertifikasına sahiptir. Gaz yakan cihazlarımızın tüm testleri AB onaylı akredite kuruluşlar olan TÜV ve KIWA laboratuvarlarında CE standartlarına uygun olarak yapılmıştır. İstanbul'da deneyimli kadrosu ve yüksek teknolojisiyle faaliyetine devam eden firmamız 46 yıllık tecrübesi ve KALİTE ismiyle özdeşleşen ürünleri ile sektörde aranan bir firma olmayı başarmıştır.

ABOUT US

In 1977, our company started to manufacture industrial kitchen equipments in Istanbul and took its place in the sector. Our company has the vision of quality, customer satisfaction and continuous technological development from the day that it was founded. In line with the expectations and demands of our customers, our company aims to continuously improve its products in terms of diversity, functionality, cooking performance and finishing. In our catalog, all products are CE certified. All tests of our gas burning devices have been carried out in accordance with CE standards in TÜV and KIWA laboratories, which are accredited by EU accredited organizations. Our company continues its activities with its experienced staff and high technology in Istanbul, has succeeded to become an expedient company in the sector with its 46 years of experience and products identified with the name of QUALITY.



“

46 yıllık tecrübemizle 50'den fazla
ülkeye ihracat yapıyoruz...

”



46 years of experience,
more than 50 countries



İÇİNDEKİLER / CONTENTS

600 SERİSİ / 600 SERIE

Makarna Haşlama, Elektrikli / Pasta Cooker, Electrical.....	7
Fritöz, Elektrikli / Fryer, Electrical.....	8
Patates Dinlendirme, Elektrikli / Chips Scuttle, Electrical.....	9
Ocak, Gazlı / Cooker, Gas.....	10
Ocak, Elektrikli / Cooker, Electrical.....	11
Pleyt Izgara, Gazlı / Plate Grill, Gas.....	12
Pleyt Izgara, Gazlı, Krom Kaplı,T / Plate Grill, Gas, Chrome Covered, T.....	13
Pleyt Izgara, Elektrikli / Plate Grill, Electrical.....	14
Pleyt Izgara, Elektrikli, Krom Kaplı / Plate Grill, Electrical, Chrome Covered.....	15
Lavtaş Izgara, Gazlı / Lav Stone Grill, Gas.....	16
Benmari, Elektrikli / Bain-Marie, Electrical.....	17
Nötr Tezgah / Neutral Counter.....	18
Snack Seri Stand / Snack Serie Stand.....	19

700 SERİSİ / 700 SERIE

Fritöz, Mono Blok, Gazlı / Fryer, Mono Block, Gas.....	21
Fritöz, Elektrikli / Fryer, Electrical.....	22
Fritöz, Mono Blok, Elektrikli / Fryer, Mono Block, Electrical.....	23
Makarna Haşlama, Elektrikli / Pasta Cooker, Electrical.....	24
Makarna Haşlama, Mono Blok, Elektrikli / Pasta Cooker, Mono Block, Electrical.....	25
Makarna Haşlama, Mono Blok, Gazlı / Pasta Cooker, Mono Block, Gas.....	26
Patates Dinlendirme, Elektrikli / Chips Scuttle, Electrical.....	27
Ocak, Gazlı / Cooker, Gas.....	28
Tek Sıra Ocak, Gazlı / Single Row Cooker, Gas.....	29
Ocak, Elektrikli / Cooker, Electrical.....	30
Kare Ocak, Elektrikli / Square Cooker, Electrical.....	31
Wok Ocak, Gazlı / Wok Cooker, Gas.....	32
Kuzine, Gazlı / Cooker with Oven, Gas.....	33
Kuzine, Elektrikli / Cooker with Oven, Electrical.....	34
Kuzine, Gazlı & Elektrikli / Cooker with Oven, Gas & Electrical.....	35
Pleyt Izgara, Gazlı / Plate Grill, Gas.....	36
Pleyt Izgara, Gazlı, Krom Kaplı, T / Plate Grill, Gas, Chrome Covered, T.....	37
Pleyt Izgara, Elektrikli / Plate Grill, Electrical.....	38
Pleyt Izgara, Elektrikli, Krom Kaplı / Plate Grill, Electrical, Chrome Covered.....	39
Lavtaş Izgara, Gazlı / Lav Stone Grill, Gas.....	40
Sulu Izgara, Gazlı / Vapour Grill, Gas.....	41
Sulu Izgara, Gazlı, T Model / Vapour Grill, Gas, T Model.....	42
Sulu Izgara, Gazlı, T Model, Pleyt Modüllü /Vapour Grill, Gas, T Model, With Plate Module.....	43
Benmari, Elektrikli / Bain-Marie, Electrical.....	44
Nötr Tezgah / Neutral Counter.....	45
Snack Seri Stand / Snack Serie Stand.....	46

900 SERİSİ / 900 SERIE

Ocak, Gazlı / Cooker, Gas.....	48
Ocak, Mono Blok, Gazlı / Cooker, Mono Block, Gas.....	49
Kuzine, Gazlı / Cooker with Oven, Gas.....	50
Kuzine, Gazlı & Elektrikli / Cooker with Oven, Gas & Electrical.....	51
Pleyt Izgara, Gazlı / Plate Grill, Gas.....	52
Pleyt Izgara, Mono Blok, Gazlı / Plate Grill, Mono Block, Gas.....	53
Pleyt Izgara, Elektrikli / Plate Grill, Electrical.....	54
Pleyt Izgara, Mono Blok, Elektrikli / Plate Grill, Mono Block, Electrical.....	55
Lavataş Izgara, Mono Blok, Gazlı / Lava Stone Grill, Mono Block, Gas.....	56
Sulu Izgara, Mono Blok, Gazlı, T Model / Vapour Grill, Mono Block, Gas, T Model.....	57
Fritöz, Mono Blok, Elektrikli / Fryer, Mono Block, Electrical.....	58
Snack Seri Stand / Snack Serie Stand.....	59

MANGAL / BARBECUE

Mangal, Kömürlü, Filtreli / Barbecue, Charcoal, With Filter.....	61
--	----

DÖNER ROBOTLARI / DONER ROBOTS

Döner Robotu, Gazlı / Doner Robot, Gas.....	63
Döner Robotu, Elektrikli / Doner Robot, Electrical.....	64

İÇİNDEKİLER / CONTENTS

DÖNER OCAKLARI / DONER KEBAB GRILLS

Gazlı Döner Ocağı, Altan Motorlu / Gas Doner Grill, Bottom Motor.....	66
Elektrikli Döner Ocağı, Altan Motorlu / Electrical Doner Grill, Bottom Motor.....	73
Gazlı Döner Ocağı, Üstten Motorlu / Gas Doner Grill, Top Motor.....	76
Elektrikli Döner Ocağı, Üstten Motorlu / Electrical Doner Grill, Top Motor.....	78
Gazlı Döner Ocağı, Motorsuz / Gas Doner Grill, Without Motor.....	80
Elektrikli Döner Ocağı, Motorsuz / Electrical Doner Grill, Without Motor.....	82
Döner Ocağı Aksesuarları / Accessories for Doner Kebab Grills.....	84

PİZZA FIRINLARI / PIZZA OVENS

ELEKTRİKLİ ANALOG KONTROL PİZZA FIRINLARI / ELECTRICAL ANALOG CONTROL PIZZA OVENS	
62 x 62 cm.....	87
72 x 72 cm.....	88
62 x 93 cm Derin Model / Deep Model.....	89
72 x 108 cm Derin Model / Deep Model.....	90
93 x 62 cm Geniş Model / Wide Model.....	91
108 x 72 cm Geniş Model / Wide Model.....	92
108 x 108 cm.....	93
ELEKTRİKLİ BASIC PİZZA FIRINLARI / ELECTRICAL BASIC PIZZA OVENS	
62 x 62 cm Basic Model / Basic Model.....	95
68 x 68 cm Basic Model / Basic Model.....	96
93 x 62 cm Basic Geniş Model / Basic Wide Model.....	97
72 x 72 cm Taş Kaplamalı Model / Stone Covered Model.....	98
ELEKTRİKLİ DİJİTAL KONTROL PİZZA FIRINLARI / ELECTRICAL DIGITAL CONTROL PIZZA OVENS	
62 x 62 cm.....	101
72 x 72 cm.....	102
62 x 93 cm Derin Model / Deep Model.....	103
72 x 108 cm Derin Model / Deep Model.....	104
93 x 62 cm Geniş Model / Wide Model.....	105
108 x 72 cm Geniş Model / Wide Model.....	106
108 x 108 cm.....	107
GAZLI PİZZA FIRINLARI / GAS PIZZA OVENS	
72 x 72 cm.....	109
123 x 92 cm.....	109
PİZZA FIRINI AKSESUARLARI / ACCESSORIES FOR PIZZA OVEN	
Pizza Fırını Masası / Table for Pizza Oven.....	110
Pizza Fırını Masası, Çekmeceli / Table for Pizza Oven, with Drawer.....	111
Pizza Fırını Davlumbazı, Motorsuz / Hood for Pizza Oven, without Motor.....	112
Pizza Fırını Davlumbazı, Motorlu / Hood for Pizza Oven, with Motor.....	113

PİLİÇ ÇEVİRME MAKİNELERİ / CHICKEN ROTISSERIE MACHINES

Piliç Çevirme Makinesi, Gazlı / Chicken Rotisserie Machine, Gas.....	115
Piliç Çevirme Makinesi, Elektrikli / Chicken Rotisserie Machine, Electrical.....	118
Piliç Çevirme Makinesi Aksesuarları / Accessories for Chicken Rotisserie Machine.....	119

KIZARMIŞ PİLİÇ EKİPMANLARI / FRIED CHICKEN EQUIPMENT

Piliç Nemlendirmeli Isıtıcı, Set Üstü / Chicken Humidified Warmer, Countertop.....	121
Paneleme Makinesi / Breeding Machine.....	122

SERVİS ÜNİTELERİ / SERVICE UNITS

Sıcak Servis Üniteleri, Benmari / Hot Service Units, Bain-Marie.....	124
Soğuk Servis Üniteleri / Cold Service Units.....	126
Nötr Servis Ünitesi / Neutral Service Unit.....	128

SALAMANDER / SALAMANDER

Chef Grill.....	130
Pita Fırını (Salamander), Gazlı / Pita Oven (Salamander), Gas.....	131
Pita Fırını (Salamander), Elektrikli / Pita Oven (Salamander), Electrical.....	132
Salamander, Elektrikli / Salamander, Electrical.....	133

KAFETERYA / CAFE

Tost Makinesi / Contact Grill.....	135
Konveyörlü Ekmek Kızartma Makinesi / Conveyor Toaster.....	138
Benmari Sulu, Yuvarlak Kap / Bain-Marie Vapour, Round Pot.....	139
Patates Dinlendirme, Katlanır Kapaklı / Chips Scuttle, Folding Lid.....	139
Yağ Ayrıştırıcı / Grease Separator.....	140

600 SERİSİ

600 SERIE



Makarna Haşlama, Elektrikli / Pasta Cooker, Electrical

Fritöz, Elektrikli / Fryer, Electrical

Patates Dinlendirme, Elektrikli / Chips Scuttle, Electrical

Ocak, Gazlı / Cooker, Gas

Ocak, Elektrikli / Cooker, Electrical

Pleyt Izgara, Gazlı / Plate Grill, Gas

Pleyt Izgara, Gazlı, Krom Kaplı, T / Plate Grill, Gas, Chrome Covered, T

Pleyt Izgara, Elektrikli / Plate Grill, Electrical

Pleyt Izgara, Elektrikli, Krom Kaplı / Plate Grill, Electrical, Chrome Covered

Lavtaş Izgara, Gazlı / Lav Stone Grill, Gas

Benmari, Elektrikli / Bain-Marie, Electrical

Nötr Tezgah / Neutral Counter

Snack Seri Stand / Snack Serie Stand

MAKARNA HAŞLAMA, ELEKTRİKLİ
PASTA COOKER, ELECTRICAL

PC4060E



TR

- Hazne kapasitesi 12 litredir.
- 30-120 °C termostatu kullanılmaktadır.
- Su dolum musluğu ve tahliye vanası vardır.

EN

- Water capacity of each bowl is 12 liters.
- Equipped with 30-120 °C thermostat.
- Equipped with water filling tap and evacuation valve.

PRODUCT CODE ÜRÜN KODU	PRODUCT NAME ÜRÜN ADI	Capacity Kapasite	Voltage Gerilim	Temperature Sıcaklık	Power Güç	Dimension (W x D x H) Ürün Ölçüsü (G x D x Y)	Net Weight Net Ağırlık	Price Fiyat
PC4060E	Makarına Haşlama, Elektrikli Pasta Cooker, Electrical	12 lt	400 V	110 °C	4,5 kW	400 x 600 x 290 mm	17 kg	

**FRİTÖZ, ELEKTRİKLİ
FRYER, ELECTRICAL****F4060E****TR**

- Hazne kapasitesi 12 litredir.
- 230 °C resetli güvenlik termostatu kullanılmaktadır.
- 180 °C termostat kullanılmaktadır.
- Askı tertibatı güvenlik sviçlidir.
- Rezistanslar yukarı yönde kaldırılarak sabitlenebilir ve böylece kolay temizlik imkanı sağlar.
- Yağ haznesinin altında bulunan emniyetli yağ tahliyesi sayesinde yağ boşaltımı kolayca yapılmakta ve olası kazaların önüne geçilmektedir.

EN

- Fat capacity of each bowl is 12 liters.
- Equipped with 230 °C reset security thermostat.
- Equipped with 180 °C thermostat.
- Equipped with security switch at resistance rack.
- Resistance can be lift and hang up to top rack easily for easy cleaning.
- Equipped with safety fat remove tap to prevent potential accidents. Easy and safe to remove fat with the adjustable tap handle.

**F6060E**

PRODUCT CODE ÜRÜN KODU	PRODUCT NAME ÜRÜN ADI	Capacity Kapasite	Voltage Gerilim	Temperature Sıcaklık	Power Güç	Dimension (W x D x H) ÜRÜN ÖLÇÜSÜ (G x D x Y)	Net Weight Net Ağırlık	Price Fiyat
F4060E	Fritöz, Elektrikli Fryer, Electrical	12 lt	400 V	180 °C	9 kW	400 x 600 x 290 mm	17 kg	
F6060E	Fritöz, Elektrikli Fryer, Electrical	12 + 12 lt	400 V	180 °C	18 kW	600 x 600 x 290 mm	32 kg	

PATATES DİNLENDİRME, ELEKTRİKLİ
CHIPS SCUTTLE, ELECTRICAL

CS4060E

TR

- Infrared seramik ısıtıcı.
- Paslanmaz çelik gövde.
- Hazne kapasitesi 3 x GN ¼ 120
- Kızarmış patateslerin sıcak bekletilmesini sağlar.
- Kızarmış patateslerin yağının süzülmesini sağlar.
- Kullanım rahatlığı sağlayan ergonomik dizayna sahiptir.
- Profesyonel kullanım için uygundur.
- Kolay temizlenebilir ve hijyeniktir.

EN

- Infrared ceramic heater.
- Stainless steel body.
- Bowl capacity 3 x GN ¼ 120
- It keeps chips hot.
- It provides to strain the oil of chips.
- It has an ergonomic design that provides ease of use.
- Suitable for professional use.
- Easy to clean and hygienic.



PRODUCT CODE ÜRÜN KODU	PRODUCT NAME ÜRÜN ADI	Capacity Kapasite	Voltage Gerilim	Power Güç	Dimension (W x D x H) Ürün Ölçüsü (G x D x Y)	Net Weight Net Ağırlık	Price Fiyat
CS4060E	Patates Dinlendirme, Elektrikli Chips Scuttle, Electrical	3 x GN 1/4 120	230 V	1,00 kW	400 x 600 x 290 mm	13 kg	

**OCAK, GAZLI
COOKER, GAS****C4060G****TR**

- 2 ve 4 brülörlü modeli vardır.
- Gaz muslukları emniyet ventillidir.
- Termokupl ve pilot ateşleme tertibatı vardır.
- Her bir brülör birbirinden bağımsız kontrol edilir.
- Kolay temizlenebilir, sağlam ve hijyeniktir.

EN

- 2 and 4 burner models are available.
- Equipped with safety valves.
- Equipped with thermocouple and pilot ignition unit.
- Each gas burner has own control button.
- Easy cleaning, durable and hygienic.

**C6060G**

PRODUCT CODE ÜRÜN KODU	PRODUCT NAME ÜRÜN ADI	Dimension (W x D x H) Ürün Ölçüsü (G x D x Y)	Gas Consumption Natural Gas / Propane Gaz Sarfiyatı Doğalgaz / Propan	Power Güç	Net Weight Net Ağırlık	Price Fiyat
C4060G	Ocak, Gazlı Cooker, Gas	400 x 600 x 290 mm	1,374 m ³ /h / 0,428 kg/h	13 kW	19 kg	
C6060G	Ocak, Gazlı Cooker, Gas	600 x 600 x 290 mm	2,748 m ³ /h / 0,856 kg/h	26 kW	29 kg	

OCAK, ELEKTRİKLİ
COOKER, ELECTRICAL

TR

- 2 ve 4 ısı plakalı modelleri vardır.
- Üst seviye pişirme performansı ve homojen sıcaklık dağılımı sağlar.
- Plakaların her biri ayrı ayrı kademeli şalterle kontrol edilir.
- Her ısı plakasında aşırı ısı termiği mevcuttur. Bu termik sayesinde aşırı ısınma durumunda elektrikli keserek ısı plakasının zarar görmesini engeller.
- Her ısı plakasında 90-450 °C aralığında kontrol sağlayan 6 konumlu şalter vardır.

EN

- 2 and 4 plates models are available.
- Advanced cooking performance and homogeneous heat distribution.
- Each plates are adjustable by multiple control switches.
- Each heating plate has its own overheat thermic. In case of overheating, power cut will be in effect, automatically for protecting plates.
- Each cooker has own switch with 6 steps, controlling the heat between 90-450 °C.



C4060E



C6060E



PRODUCT CODE ÜRÜN KODU	PRODUCT NAME ÜRÜN ADI	Dimension (W x D x H) Ürün Ölçüsü (G x D x Y)	Power Güç	Voltage Gerilim	Net Weight Net Ağırlık	Price Fiyat
C4060E	Ocak, Yuvarlak, Elektrikli Cooker, Round, Electrical	400 x 600 x 290 mm	4 kW	400 V/ 50 Hz	14 kg	
C6060E	Ocak, Yuvarlak, Elektrikli Cooker, Round, Electrical	600 x 600 x 290 mm	7kW	400 V/ 50 Hz	28 kg	

PLEYT IZGARA, GAZLI
PLATE GRILL, GAS

GF4060G

GG4060G

GS6060G

TR

- Üst seviye pişirme performansı ve homojen sıcaklık dağılımı sağlamaktadır.
- 12 mm kalınlığında pleyt izgara sayesinde tasarruflu pişirme sağlanmaktadır.
- Düz, oluklu ve yarı oluklu seçenekleriyle çeşitli pişirme olanakları sunmaktadır.
- Geniş yağ tahliye deliği sayesinde atık yağ kolayca yağ haznesine ulaşır.
- Gaz muslukları emniyet ventillidir.
- Termokupl ve pilot ateşleme tertibatı vardır.
- Manyetolu çakmağı vardır.

EN

- Advanced cooking performance and homogeneous heat distribution.
- Economic grilling with 12 mm plate thickness.
- Various grilling options with flat, grooved or semi grooved models.
- Waste oil easily reach the oil bowl due to its wide oil wasteway hole.
- Equipped with safety valves.
- Equipped with thermocouple and pilot ignition unit.
- Equipped with piezoelectric ignition system for each burners.

PRODUCT CODE ÜRÜN KODU	PRODUCT NAME ÜRÜN ADI	Dimension (W x D x H) Ürün Ölçüsü (G x D x Y)	Gas Consumption Natural Gas / Propane Gaz Sarfiyatı Doğalgaz / Propan	Power Güç	Net Weight Net Ağırlık	Price Fiyat
GF4060G	Pleyt Izgara, Gazlı, Düz Plate Grill, Gas, Flat Top	400 x 600 x 290 mm	0,641 m ³ /h / 0,141 kg/h	4,6 kW	33 kg	
GG4060G	Pleyt Izgara, Gazlı, Oluklu Plate Grill, Gas, Grooved Top	400 x 600 x 290 mm	0,641 m ³ /h / 0,141 kg/h	4,6 kW	33 kg	
GF6060G	Pleyt Izgara, Gazlı, Düz Plate Grill, Gas, Flat Top	600 x 600 x 290 mm	1,282 m ³ /h / 0,282 kg/h	9,2 kW	56 kg	
GG6060G	Pleyt Izgara, Gazlı, Oluklu Plate Grill, Gas, Grooved Top	600 x 600 x 290 mm	1,282 m ³ /h / 0,282 kg/h	9,2 kW	56 kg	
GS6060G	Pleyt Izgara, Gazlı, Yarı Oluklu Plate Grill, Gas, Semi-Grooved Top	600 x 600 x 290 mm	1,282 m ³ /h / 0,282 kg/h	9,2 kW	56 kg	
GF9060G	Pleyt Izgara, Gazlı, Düz Plate Grill, Gas, Flat Top	900 x 600 x 290 mm	1,923 m ³ /h / 0,423 kg/h	13,8 kW	84 kg	
GG9060G	Pleyt Izgara, Gazlı, Oluklu Plate Grill, Gas, Grooved Top	900 x 600 x 290 mm	1,923 m ³ /h / 0,423 kg/h	13,8 kW	84 kg	
GS9060G	Pleyt Izgara, Gazlı, Yarı Oluklu Plate Grill, Gas, Semi-Grooved Top	900 x 600 x 290 mm	1,923 m ³ /h / 0,423 kg/h	13,8 kW	84 kg	
GF1060G	Pleyt Izgara, Gazlı, Düz Plate Grill, Gas, Flat Top	1000 x 600 x 290 mm	1,923 m ³ /h / 0,423 kg/h	13,8 kW	92 kg	
GG1060G	Pleyt Izgara, Gazlı, Oluklu Plate Grill, Gas, Grooved Top	1000 x 600 x 290 mm	1,923 m ³ /h / 0,423 kg/h	13,8 kW	92 kg	
GS1060G	Pleyt Izgara, Gazlı, Yarı Oluklu Plate Grill, Gas, Semi-Grooved Top	1000 x 600 x 290 mm	1,923 m ³ /h / 0,423 kg/h	13,8 kW	92 kg	
GF1260G	Pleyt Izgara, Gazlı, Düz Plate Grill, Gas, Flat Top	1200 x 600 x 290 mm	2,564 m ³ /h / 0,564 kg/h	18,4 kW	112 kg	
GG1260G	Pleyt Izgara, Gazlı, Oluklu Plate Grill, Gas, Grooved Top	1200 x 600 x 290 mm	2,564 m ³ /h / 0,564 kg/h	18,4 kW	112 kg	
GS1260G	Pleyt Izgara, Gazlı, Yarı Oluklu Plate Grill, Gas, Semi-Grooved Top	1200 x 600 x 290 mm	2,564 m ³ /h / 0,564 kg/h	18,4 kW	112 kg	

PLEYT IZGARA, GAZLI, KROM KAPLI, T
PLATE GRILL, GAS, CHROME COVERED, T

GF6060GC



GG6060GC

TR

- Pişirme yüzeyi sert krom kaplamadır.
- Üst seviye pişirme performansı ve homojen sıcaklık dağılımı sağlamaktadır.
- 12 mm kalınlığında pleyt ızgara sayesinde tasarruflu pişirme sağlanmaktadır.
- Düz, oluklu ve yarı oluklu seçenekleriyle çeşitli pişirme olanakları sunmaktadır.
- Geniş yağ tahliye deliği sayesinde atık yağ kolayca yağ haznesine ulaşır.
- Gaz muslukları emniyet ventillidir.
- Termokupl ve pilot ateşleme tertibatı vardır.
- Manyetolu çakmağı vardır.

EN

- Cooking surface is covered by hard chrome.
- Advanced cooking performance and homogeneous heat distribution.
- Economic grilling with 12 mm plate thickness.
- Various grilling options with flat, grooved or semi grooved models.
- Waste oil easily reach the oil bowl due to its wide oil wasteway hole.
- Equipped with safety valves.
- Equipped with thermocouple and pilot ignition unit.
- Equipped with piezoelectric ignition system for each burners.

PRODUCT CODE ÜRÜN KODU	PRODUCT NAME ÜRÜN ADI	Dimension (W x D x H) Ürün Ölçüsü (G x D x Y)	Gas Consumption Natural Gas / Propane Gaz Sarfiyatı Doğalgaz / Propan	Power Güç	Net Weight Net Ağırlık	Price Fiyat
GF4060GC	Pleyt Izgara, Gazlı, Düz, Krom Kaplı, T Plate Grill, Gas, Flat Top, Chrome Covered, T	400 x 600 x 290 mm	0,641 m ³ /h / 0,141 kg/h	4,6 kW	33 kg	
GG4060GC	Pleyt Izgara, Gazlı, Oluklu, Krom Kaplı, T Plate Grill, Gas, Grooved Top, Chrome Covered, T	400 x 600 x 290 mm	0,641 m ³ /h / 0,141 kg/h	4,6 kW	33 kg	
GF6060GC	Pleyt Izgara, Gazlı, Düz, Krom Kaplı, T Plate Grill, Gas, Flat Top, Chrome Covered, T	600 x 600 x 290 mm	1,282 m ³ /h / 0,282 kg/h	9,2 kW	56 kg	
GG6060GC	Pleyt Izgara, Gazlı, Oluklu, Krom Kaplı, T Plate Grill, Gas, Grooved Top, Chrome Covered, T	600 x 600 x 290 mm	1,282 m ³ /h / 0,282 kg/h	9,2 kW	56 kg	
GS6060GC	Pleyt Izgara, Gazlı, Yarı Oluklu, Krom Kaplı, T Plate Grill, Gas, Semi-Grooved Top, Chrome Covered, T	600 x 600 x 290 mm	1,282 m ³ /h / 0,282 kg/h	9,2 kW	56 kg	
GF9060GC	Pleyt Izgara, Gazlı, Düz, Krom Kaplı, T Plate Grill, Gas, Flat Top, Chrome Covered, T	900 x 600 x 290 mm	1,923 m ³ /h / 0,423 kg/h	13,8 kW	84 kg	
GG9060GC	Pleyt Izgara, Gazlı, Oluklu, Krom Kaplı, T Plate Grill, Gas, Grooved Top, Chrome Covered, T	900 x 600 x 290 mm	1,923 m ³ /h / 0,423 kg/h	13,8 kW	84 kg	
GS9060GC	Pleyt Izgara, Gazlı, Yarı Oluklu, Krom Kaplı, T Plate Grill, Gas, Semi-Grooved Top, Chrome Covered, T	900 x 600 x 290 mm	1,923 m ³ /h / 0,423 kg/h	13,8 kW	84 kg	
GF1060GC	Pleyt Izgara, Gazlı, Düz, Krom Kaplı, T Plate Grill, Gas, Flat Top, Chrome Covered, T	1000 x 600 x 290 mm	1,923 m ³ /h / 0,423 kg/h	13,8 kW	92 kg	
GG1060GC	Pleyt Izgara, Gazlı, Oluklu, Krom Kaplı, T Plate Grill, Gas, Grooved Top, Chrome Covered, T	1000 x 600 x 290 mm	1,923 m ³ /h / 0,423 kg/h	13,8 kW	92 kg	
GS1060GC	Pleyt Izgara, Gazlı, Yarı Oluklu, Krom Kaplı, T Plate Grill, Gas, Semi-Grooved Top, Chrome Covered, T	1000 x 600 x 290 mm	1,923 m ³ /h / 0,423 kg/h	13,8 kW	92 kg	
GF1260GC	Pleyt Izgara, Gazlı, Düz, Krom Kaplı, T Plate Grill, Gas, Flat Top, Chrome Covered, T	1200 x 600 x 290 mm	2,564 m ³ /h / 0,564 kg/h	18,4 kW	112 kg	
GG1260GC	Pleyt Izgara, Gazlı, Oluklu, Krom Kaplı, T Plate Grill, Gas, Grooved Top, Chrome Covered, T	1200 x 600 x 290 mm	2,564 m ³ /h / 0,564 kg/h	18,4 kW	112 kg	
GS1260GC	Pleyt Izgara, Gazlı, Yarı Oluklu, Krom Kaplı, T Plate Grill, Gas, Semi-Grooved Top, Chrome Covered, T	1200 x 600 x 290 mm	2,564 m ³ /h / 0,564 kg/h	18,4 kW	112 kg	

PLEYT IZGARA, ELEKTRİKLİ
PLATE GRILL, ELECTRICAL

GF6060E

GS6060E

GF4060E

GG4060E

GG6060E

TR

- Üst seviye pişirme performansı ve homojen sıcaklık dağılımı sağlamaktadır.
- 12 mm kalınlığında pleyt ızgara sayesinde tasarruflu pişirme sağlamaktadır.
- Düz, oluklu ve yarı oluklu seçenekleriyle çeşitli pişirme olanakları sunmaktadır.
- Geniş yağ tahliye deliği sayesinde atık yağ kolayca yağ haznesine ulaşır.
- Pişirme yüzeyinin sıcaklığı termostat kontrolü ile 50-300 °C arasında ayarlanabilmektedir.

EN

- Best cooking performance and homogeneous heat distribution.
- Economic grilling with 12mm plate thickness.
- Various grilling options with flat, grooved or semi grooved models.
- Waste oil easily reach the oil bowl due to its wide oil wasteway hole.
- Cooktop temperature is adjustable between 50-300 °C with thermostat control.

PRODUCT CODE ÜRÜN KODU	PRODUCT NAME ÜRÜN ADI	Dimension (W x D x H) Ürün Ölçüsü (G x D x Y)	Voltage Gerilim	Temperature Sıcaklık	Power Güç	Net Weight Net Ağırlık	Price Fiyat
GF4060E	Pleyt Izgara, Elektrikli, Düz Plate Grill, Electrical, Flat Top	400 x 600 x 290 mm	400 V / 50 Hz	300 °C	4,0 kW	40 kg	
GG4060E	Pleyt Izgara, Elektrikli, Oluklu Plate Grill, Electrical, Grooved Top	400 x 600 x 290 mm	400 V / 50 Hz	300 °C	4,0 kW	40 kg	
GF6060E	Pleyt Izgara, Elektrikli, Düz Plate Grill, Electrical, Flat Top	600 x 600 x 290 mm	400 V / 50 Hz	300 °C	8,0 kW	47 kg	
GG6060E	Pleyt Izgara, Elektrikli, Oluklu Plate Grill, Electrical, Grooved Top	600 x 600 x 290 mm	400 V / 50 Hz	300 °C	8,0 kW	47 kg	
GS6060E	Pleyt Izgara, Elektrikli, Yarı Oluklu Plate Grill, Electrical, Semi-Grooved Top	600 x 600 x 290 mm	400 V / 50 Hz	300 °C	8,0 kW	47 kg	

PLEYT IZGARA, ELEKTRİKLİ, KROM KAPLI
PLATE GRILL, ELECTRICAL, CHROME COVERED

GF6060EC



GS6060EC



GF4060EC



GG4060EC



GG6060EC



TR

- Pişirme yüzeyi sert krom kaplamadır.
- Üst seviye pişirme performansı ve homojen sıcaklık dağılımı sağlamaktadır.
- 12 mm kalınlığında pleyt ızgara sayesinde tasarruflu pişirme sağlamaktadır.
- Düz, oluklu ve yarı oluklu seçenekleriyle çeşitli pişirme olanakları sunmaktadır.
- Geniş yağ tahliye deliği sayesinde atık yağ kolayca yağ haznesine ulaşır.
- Pişirme yüzeyinin sıcaklığı termostat kontrolü ile 50-300 °C arasında ayarlanabilmektedir.

EN

- Cooking surface is covered by hard chrome.
- Best cooking performance and homogeneous heat distribution.
- Economic grilling with 12mm plate thickness.
- Various grilling options with flat, grooved or semi grooved models.
- Waste oil easily reach the oil bowl due to its wide oil wasteway hole.
- Cooktop temperature is adjustable between 50-300 °C with thermostat control.

PRODUCT CODE ÜRÜN KODU	PRODUCT NAME ÜRÜN ADI	Dimension (W x D x H) ÜRÜN ÖLÇÜSÜ (G x D x Y)	Voltage Gerilim	Temperature Sıcaklık	Power Güç	Net Weight Net Ağırlık	Price Fiyat
GF4060EC	Pleyt Izgara, Elektrikli, Düz, Krom Kaplı Plate Grill, Electrical, Flat Top, Chrome Covered	400 x 600 x 290 mm	400 V / 50 Hz	300 °C	4,0 kW	40 kg	
GG4060EC	Pleyt Izgara, Elektrikli, Oluklu, Krom Kaplı Plate Grill, Electrical, Grooved Top, Chrome Covered	400 x 600 x 290 mm	400 V / 50 Hz	300 °C	4,0 kW	40 kg	
GF6060EC	Pleyt Izgara, Elektrikli, Düz, Krom Kaplı Plate Grill, Electrical, Flat Top, Chrome Covered	600 x 600 x 290 mm	400 V / 50 Hz	300 °C	8,0 kW	47 kg	
GG6060EC	Pleyt Izgara, Elektrikli, Oluklu, Krom Kaplı Plate Grill, Electrical, Grooved Top, Chrome Covered	600 x 600 x 290 mm	400 V / 50 Hz	300 °C	8,0 kW	47 kg	
GS6060EC	Pleyt Izgara, Elektrikli, Yarı Oluklu, Krom Kaplı Plate Grill, Electrical, Semi-Grooved Top, Chrome Covered	600 x 600 x 290 mm	400 V / 50 Hz	300 °C	8,0 kW	47 kg	

**LAVTAŞ IZGARA, GAZLI
LAV STONE GRILL, GAS****LG4060G****TR**

- Pişirme yüzeyi sac ızgara veya döküm olarak tercih edilebilir.
- 1 ve 2 brülörlü modeli vardır.
- Gaz muslukları emniyet ventillidir.
- Termokupl ve pilot ateşleme tertibatı vardır.
- Manyetolu çakmağı vardır.
- Özel tasarım v tipi ızgara ve döküm sayesinde pişirme esnasında oluşan atık yağ kolayca ön tarafta yer alan hazneye aktarılmaktadır.
- Yükseklik ayarı yapılabilen ızgara sayesinde pişirme hızı ve şiddeti ayarlanabilir.

EN

- Cooking surface can be preferred as stainless steel grill or cast.
- 1 and 2 burner models are available.
- Equipped with safety valves.
- Equipped with thermocouple and pilot ignition unit
- Equipped piezoelectric ignition system for each burners.
- Special design v shaped stainless steel grill and cast prevents oil dripping to the burners. Easy to transfer collected greases from front collection tray.
- Distance from burner and back part of cast iron grills are adjustable by front handled lever.

**LG6060G**

PRODUCT CODE ÜRÜN KODU	PRODUCT NAME ÜRÜN ADI	Dimension (W x D x H) Ürün Ölçüsü (G x D x Y)	Gas Consumption Natural Gas / Propane Gaz Sarfiyatı Doğalgaz / Propan	Power Güç	Net Weight Net Ağırlık	Price Fiyat
LG4060G	Lavtaş Izgara, Gazlı Lav Stone Grill, Gas	400 x 600 x 290 mm	0,730 m ³ /h / 0,211 kg/h	6,9 kW	46 kg	
LG6060G	Lavtaş Izgara, Gazlı Lav Stone Grill, Gas	600 x 600 x 290 mm	1,460 m ³ /h / 0,422 kg/h	13,8 kW	73 kg	

BENMARİ, ELEKTRİKLİ
BAIN-MARIE, ELECTRICAL

BM4060E

TR

- Sıcak buhar sayesinde yiyeceklerin servis sıcaklığında bekletilmesini sağlar.
- Paslanmaz çelik gövde ve su haznesi.
- Tüp rezistans kullanılmaktadır.
- Termostatik kontrol.
- Su dolumu manuel olarak yapılabilir.
- Su boşaltma musluğu bulunmaktadır.
- Hazne kapasitesi 3 x GN ¼ 150
- Kullanım rahatlığı sağlayan ergonomik dizayna sahiptir.
- Profesyonel kullanım için uygundur.
- Kolay temizlenebilir ve hijyeniktir.

EN

- It keeps foods at the service temperature through hot steam.
- Stainless steel body and water tank.
- Tube resistance is used.
- Thermostatic control.
- Water filling can be done manually.
- There is a drain pipe.
- Bowl capacity 3 x GN ¼ 150
- It has an ergonomic design that provides ease of use.
- Suitable for professional use.
- Easy to clean and hygienic.



PRODUCT CODE ÜRÜN KODU	PRODUCT NAME ÜRÜN ADI	Capacity Kapasite	Voltage Gerilim	Temperature Sıcaklık	Power Güç	Dimension (W x D x H) Ürün Ölçüsü (G x D x Y)	Net Weight Net Ağırlık	Price Fiyat
BM4060E	Benmari, Elektrikli Bain-Marie, Electrical	3 x GN ¼ 150	230 V	110 °C	1,00 kW	400 x 600 x 290 mm	13 kg	

**NÖTR TEZGAH
NEUTRAL COUNTER****N4060****TR**

- Paslanmaz çelikten imal edilmiştir.
- Pişirme öncesi her türlü hazırlık için kullanılabilir.
- Kolay temizlenebilir, sağlam ve hijyeniktir.

EN

- It's made of stainless steel.
- It can be used for any preparation before cooking.
- Easy cleaning, durable and hygienic.

N6060

PRODUCT CODE ÜRÜN KODU	PRODUCT NAME ÜRÜN ADI	Dimension (W x D x H) Ürün Ölçüsü (G x D x Y)	Net Weight Net Ağırlık	Price Fiyat
N4060	Nötr Tezgah Neutral Counter	400 x 600 x 290 mm	10 kg	
N6060	Nötr Tezgah Neutral Counter	600 x 600 x 290 mm	14 kg	

SNACK SERİ STAND
SNACK SERIE STAND

CS4060



CS6060



OS4060



OS6060



DS4060



DS6060



PRODUCT CODE ÜRÜN KODU	PRODUCT NAME ÜRÜN ADI	Dimension (W x D x H) Ürün Ölçüsü (G x D x Y)	Net Weight Net Ağırlık	Price Fiyat
CS4060	Stand, Kapaklı / Stand, Cabinet	400 x 600 x 610 mm	13 kg	
CS6060	Stand, Kapaklı / Stand, Cabinet	600 x 600 x 610 mm	17 kg	
OS4060	Stand, Kapaksız / Stand, Coverless	400 x 600 x 610 mm	10 kg	
OS6060	Stand, Kapaksız / Stand, Coverless	600 x 600 x 610 mm	14 kg	
DS4060	Stand, Çekmeceli / Stand, Drawer	400 x 600 x 610 mm	17 kg	
DS6060	Stand, Çekmeceli / Stand, Drawer	600 x 600 x 610 mm	27 kg	

700 SERİSİ

700 SERIE

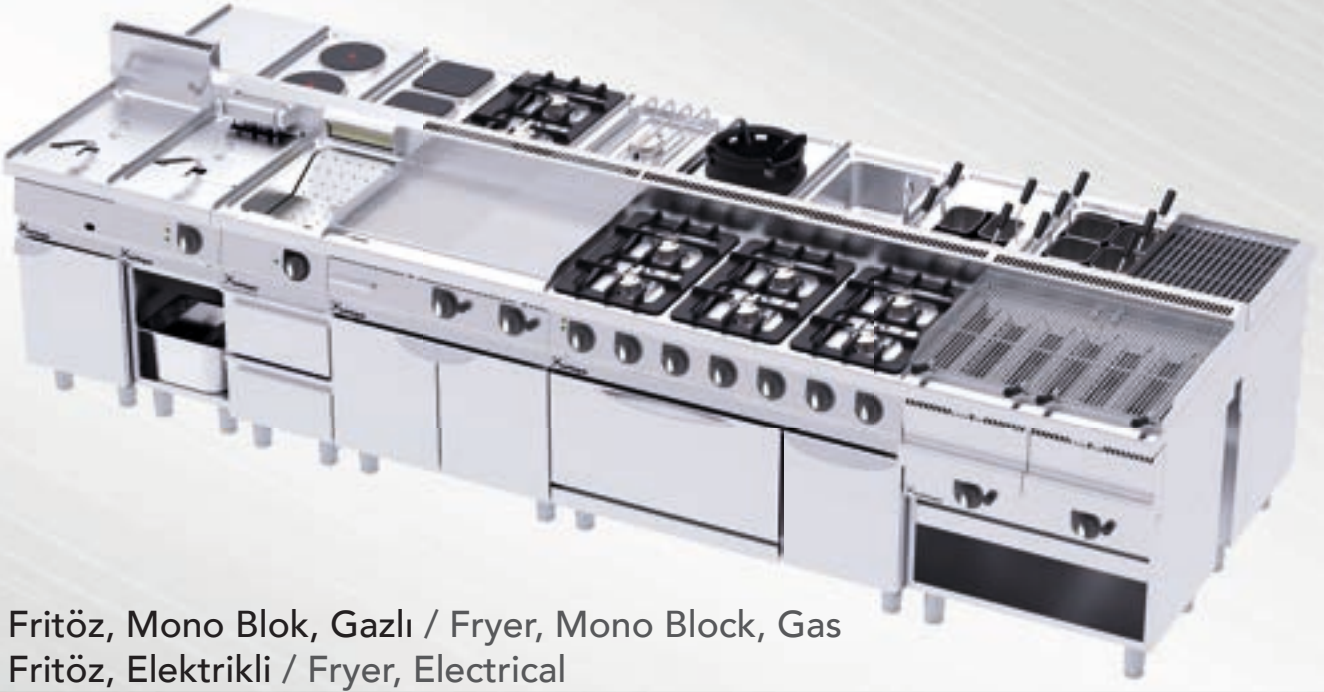

Fritöz, Mono Blok, Gazlı / Fryer, Mono Block, Gas

Fritöz, Elektrikli / Fryer, Electrical

Fritöz, Mono Blok, Elektrikli / Fryer, Mono Block, Electrical

Makarna Haşlama, Elektrikli / Pasta Cooker, Electrical

Makarna Haşlama, Mono Blok, Elektrikli / Pasta Cooker, Mono Block, Electrical

Makarna Haşlama, Mono Blok, Gazlı / Pasta Cooker, Mono Block, Gas

Patates Dinlendirme, Elektrikli / Chips Scuttle, Electrical

Ocak, Gazlı / Cooker, Gas

Tek Sıra Ocak, Gazlı / Single Row Cooker, Gas

Ocak, Elektrikli / Cooker, Electrical

Kare Ocak, Elektrikli / Square Cooker, Electrical

Wok Ocak, Gazlı / Wok Cooker, Gas

Kuzine, Gazlı / Range, Gas

Kuzine, Elektrikli / Range, Electrical

Kuzine, Gazlı & Elektrikli / Range, Gas & Electrical

Pleyt Izgara, Gazlı / Plate Grill, Gas

Pleyt Izgara, Gazlı, Krom Kaplı, T / Plate Grill, Gas, Chrome Covered, T

Pleyt Izgara, Elektrikli / Plate Grill, Electrical

Pleyt Izgara, Elektrikli, Krom Kaplı / Plate Grill, Electrical, Chrome Covered

Lavtaş Izgara, Gazlı / Lav Stone Grill, Gas

Sulu Izgara, Gazlı / Vapour Grill, Gas

Sulu Izgara, Gazlı, T Model / Vapour Grill, Gas, T Model

Sulu Izgara, Gazlı, T Model, Pleyt Modüllü / Vapour Grill, Gas, T Model, with Plate Module

Benmari, Elektrikli / Bain-Marie, Electrical

Nötr Tezgah / Neutral Counter

Snack Seri Stand / Snack Serie Stand

FRİTÖZ, MONO BLOK, GAZLI
FRYER, MONO BLOCK, GAS

TR

- Fritöz sepeti paslanmaz sac malzemeden yapılmıştır.
- Doğalgaz ve LPG ile çalışır
- Güvenlik termostatu kullanılmaktadır.
- Yağ haznesinin altında bulunan emniyetli yağ tahliyesi sayesinde yağ boşaltımı kolayca yapılmakta ve olası kazaların önüne geçilmektedir.
- Kolay temizlenebilir, paslanmaz çelik hijyenik gövde.
- Sepet için askı tertibatı.

EN

- Fryer basket is made of stainless steel.
- Naturalgas or LPG
- Equipped with security thermostat.
- Equipped with fat remove tap. Easy and safe to remove fat with the adjustable tap handle.
- Easy to clean, stainless steel hygenic body.
- Rack for frying basket.



FCS4070G



FCS8070G



PRODUCT CODE ÜRÜN KODU	PRODUCT NAME ÜRÜN ADI	Capacity Kapasite	Gas Consumption Natural Gas / Propane Gaz Sarfiyatı Doğalgaz / Propan	Temperature Sıcaklık	Power Güç	Dimension (W x D x H) Ürün Ölçüsü (G x D x Y)	Net Weight Net Ağırlık	Price Fiyat
FCS4070G	Fritöz, Mono Blok, Gazlı Fryer, Mono Block, Gas	23 lt	0,968 m ³ /h / 0,223 kg/h	190°C	9 kW	400 x 700 x 900 mm	45 kg	
FCS8070G	Fritöz, Mono Blok, Gazlı Fryer, Mono Block, Gas	23+23 lt	1,936 m ³ /h / 0,446 kg/h	190°C	18 kW	800 x 700 x 900 mm	80 kg	

**FRİTÖZ, ELEKTRİKLİ
FRYER, ELECTRICAL****F4070E****TR**

- Fritöz sepeti paslanmaz sac malzemeden yapılmıştır.
- Hazne kapasitesi 13 litredir.
- 230 °C resetli güvenlik termostatu kullanılmaktadır.
- 180 °C termostat kullanılmaktadır.
- Askı tertibatı güvenlik sviçlidir.
- Rezistanslar yukarı yönde kaldırılarak sabitlenebilir ve böylece kolay temizlik imkanı sağlar.
- Yağ haznesinin altında bulunan emniyetli yağ tahliyesi sayesinde yağ boşaltımı kolayca yapılmakta ve olası kazaların önüne geçilmektedir.

EN

- Fryer basket is made of stainless steel.
- Fat capacity of each bowl is 13 liter.
- Equipped with 230 °C reset security thermostat.
- Equipped with 180 °C thermostat.
- Equipped with security switch at resistance rack.
- Resistance can be lift and hang up to top rack easily for easy cleaning.
- Equipped with safety fat remove tap to prevent potential accidents. Easy and safe to remove fat with the adjustable tap handle.

**F8070E**

PRODUCT CODE ÜRÜN KODU	PRODUCT NAME ÜRÜN ADI	Capacity Kapasite	Voltage Gerilim	Temperature Sıcaklık	Power Güç	Dimension (W x D x H) Ürün Ölçüsü (G x D x Y)	Net Weight Net Ağırlık	Price Fiyat
F4070E	Fritöz, Elektrikli Fryer, Electrical	13 lt	400 V	180 °C	9 kW	400 x 700 x 290 mm	20 kg	
F8070E	Fritöz, Elektrikli Fryer, Electrical	13 + 13 lt	400 V	180 °C	18 kW	800 x 700 x 290 mm	37 kg	

FRİTÖZ, MONO BLOK, ELEKTRİKLİ
FRYER, MONO BLOCK, ELECTRICAL

TR

- Fritöz sepeti paslanmaz sac malzemeden yapılmıştır.
- Hazne kapasitesi 13 litredir.
- 230 °C resetli güvenlik termostatu kullanılmaktadır.
- 180 °C termostat kullanılmaktadır.
- Askı tertibatı güvenlik svçlidir.
- Rezistanslar yukarı yönde kaldırılarak sabitlenebilir ve böylece kolay temizlik imkanı sağlar.
- Yağ haznesinin altında bulunan emniyetli yağ tahliyesi sayesinde yağ boşaltımı kolayca yapılmakta ve olası kazaların önüne geçilmektedir.

EN

- Fryer basket is made of stainless steel.
- Fat capacity of each bowl is 13 liter.
- Equipped with 230 °C reset security thermostat.
- Equipped with 180 °C thermostat.
- Equipped with security switch at resistance rack.
- Resistance could be swing and hang up to top rack easily for easy cleaning.
- Equipped with fat remove tap. Easy and safe to remove fat with the adjustable tap handle.



FCS4070E



FCS8070E



PRODUCT CODE ÜRÜN KODU	PRODUCT NAME ÜRÜN ADI	Capacity Kapasite	Voltage Gerilim	Temperature Sıcaklık	Power Güç	Dimension (W x D x H) Ürün Ölçüsü (G x D x Y)	Net Weight Net Ağırlık	Price Fiyat
FCS4070E	Fritöz, Mono Blok, Elektrikli Fryer, Mono Block, Electrical	13 lt	400 V	180 °C	9 kW	400 x 700 x 900 mm	34 kg	
FCS8070E	Fritöz, Mono Blok, Elektrikli Fryer, Mono Block, Electrical	13 + 13 lt	400 V	180 °C	18 kW	800 x 700 x 900 mm	57 kg	

**MAKARNA HAŞLAMA, ELEKTRİKLİ
PASTA COOKER, ELECTRICAL****PC4070E****TR**

- Hazne kapasitesi 12 litredir.
- 30-120 °C termostati bulunmaktadır.
- Su dolum musluğu ve tahliye vanası vardır.

EN

- Water capacity of each bowl is 12 liter.
- Equipped with 30-120 °C thermostat.
- Equipped with water filling tap and evacuation valve.

**PC8070E**

PRODUCT CODE ÜRÜN KODU	PRODUCT NAME ÜRÜN ADI	Capacity Kapasite	Voltage Gerilim	Temperature Sıcaklık	Power Güç	Dimension (W x D x H) Ürün Ölçüsü (G x D x Y)	Net Weight Net Ağırlık	Price Fiyat
PC4070E	Makarna Haşlama, Elektrikli Pasta Cooker, Electrical	19 lt	400 V	110 °C	4,5 kW	400 x 700 x 290 mm	18 kg	
PC8070E	Makarna Haşlama, Elektrikli Pasta Cooker, Electrical	19 + 19 lt	400 V	110 °C	9 kW	800 x 700 x 290 mm	35 kg	

MAKARNA HAŞLAMA, MONO BLOK, ELEKTRİKLİ
PASTA COOKER, MONO BLOCK, ELECTRICAL

TR

- Hazne kapasitesi 12 litredir.
- 30-120 °C termostadı bulunmaktadır.
- Su dolum musluğu ve tahliye vanası vardır.

EN

- Water capacity of each bowl is 12 liter.
- Equipped with 30-120 °C thermostat.
- Equipped with water filling tap and evacuation valve.

⚡ PCCS4070E



⚡ PCCS8070E



PRODUCT CODE ÜRÜN KODU	PRODUCT NAME ÜRÜN ADI	Capacity Kapasite	Voltage Gerilim	Temperature Sıcaklık	Power Güç	Dimension (W x D x H) Ürün Ölçüsü (G x D x Y)	Net Weight Net Ağırlık	Price Fiyat
PCCS4070E	Makarna Haşlama, Mono Blok, Elektrikli Pasta Cooker, Mono Block, Electrical	12 lt	400 V	110 °C	4,5 kW	400 x 700 x 900 mm	32 kg	
PCCS8070E	Makarna Haşlama, Mono Blok, Elektrikli Pasta Cooker, Mono Block, Electrical	12 + 12 lt	400 V	110 °C	9 kW	800 x 700 x 900 mm	54 kg	

**MAKARNA HAŞLAMA, MONO BLOK, GAZLI
PASTA COOKER, MONO BLOCK, GAS****PCCS4070G****TR**

- Paslanmaz çelik gövde.
- Mono blok gövde.
- Doğalgaz ya da LPG uyumlu.
- 6 adet makarna sepeti
- Su boşaltma musluğu.
- Ayarlanabilir ayaklar.
- Pilot yanış sistemi
- Emniyet termostatı.

EN

- Stainless steel body.
- Mono block body
- Natural gas or LPG compatible
- 6 pieces pasta basket
- Water evacuation tap
- Adjustable feet
- Pilot combustion system
- Safety thermostat.

PRODUCT CODE ÜRÜN KODU	PRODUCT NAME ÜRÜN ADI	Capacity Kapasite	Gaz Sarfıyatı Doğalgaz / Propan Gas Consumption Natural / Propane	Temperature Sıcaklık	Power Güç	Dimension (W x D x H) ÜRÜN ÖLÇÜSÜ (G x D x Y)	Net Weight Net Ağırlık	Price Fiyat
PCCS4070G	Makarına Haşlama, Mono Blok, Gazlı Paste Cooker, Mono Block, Gas	25 lt	1,060 m ³ /h / 0,247 kg/h	110°C	4,5 kW	400 x 700 x 900 mm	45 kg	

PATATES DİNLENDİRME, ELEKTRİKLİ
CHIPS SCUTTLE, ELECTRICAL

CS4070E

TR

- Infrared seramik ısıtıcı.
- Paslanmaz çelik gövde.
- Hazne kapasitesi 3 x GN ¼ 120
- Kızarmış patateslerin sıcak bekletilmesini sağlar.
- Kızarmış patateslerin yağının süzülmesini sağlar.
- Kullanım rahatlığı sağlayan ergonomik dizayna sahiptir.
- Profesyonel kullanım için uygundur.
- Kolay temizlenebilir ve hijyeniktir.

EN

- Infrared ceramic heater.
- Stainless steel body.
- Bowl capacity 3 x GN ¼ 120
- It keeps chips hot.
- It provides to strain the oil of chips.
- It has an ergonomic design that provides ease of use.
- Suitable for professional use.
- Easy to clean and hygienic.



PRODUCT CODE ÜRÜN KODU	PRODUCT NAME ÜRÜN ADI	Capacity Kapasite	Voltage Gerilim	Power Güç	Dimension (W x D x H) Ürün Ölçüsü (G x D x Y)	Net Weight Net Ağırlık	Price Fiyat
CS4070E	Patates Dinlendirme, Elektrikli Chips Scuttle, Electrical	GN 1/1 120	230 V	1,00 kW	400 x 700 x 290 mm	15 kg	

**OCAK, GAZLI
COOKER, GAS****C4070G****C8070G****C1270G****TR**

- 2, 4 ve 6 brülörlü modelleri vardır.
- Gaz muslukları emniyet ventillidir.
- Termokupl ve pilot ateşleme tertibatı vardır.
- Her bir brülör birbirinden bağımsız kontrol edilir.
- Kolay temizlenebilir, sağlam ve hijyeniktir.

EN

- 2, 4 and 6 burner models are available.
- Equipped with safety valves.
- Equipped with thermocouple and pilot ignition unit
- Each burner has own control button.
- Easy cleaning, durable and hygienic.

PRODUCT CODE ÜRÜN KODU	PRODUCT NAME ÜRÜN ADI	Dimension (W x D x H) Ürün Ölçüsü (G x D x Y)	Gas Consumption Natural Gas / Propane Gaz Sarfiyatı Doğalgaz / Propan	Power Güç	Net Weight Net Ağırlık	Price Fiyat
C4070G	Ocak, Gazlı Cooker, Gas	400 x 700 x 290 mm	1,374 m ³ /h / 0,428 kg/h	16,1 kW	22 kg	
C8070G	Ocak, Gazlı Cooker, Gas	800 x 700 x 290 mm	2,748 m ³ /h / 0,856 kg/h	32,2 kW	34 kg	
C1270G	Ocak, Gazlı Cooker, Gas	1200 x 700 x 290 mm	4,122 m ³ /h / 1,284 kg/h	48,3 kW	46 kg	

TEK SIRA OCAK, GAZLI
SINGLE ROW COOKER, GAS

SC4070G



SC8070G



TR

- 1, 2 ve 3 brülörlü modelleri vardır.
- Gaz muslukları emniyet ventillidir.
- Termokupl ve pilot ateşleme tertibatı vardır.
- Her bir brülör birbirinden bağımsız kontrol edilir.
- Kolay temizlenebilir, sağlam ve hijyeniktir.

EN

- 1, 2 and 3 burner models are available.
- Equipped with safety valves.
- Equipped with thermocouple and pilot ignition unit
- Each burner has own control button.
- Easy cleaning, durable and hygienic.



SC1270G



PRODUCT CODE ÜRÜN KODU	PRODUCT NAME ÜRÜN ADI	Dimension (W x D x H) Ürün Ölçüsü (G x D x Y)	Gas Consumption Natural Gas / Propane Gaz Sarfıyatı Doğalgaz / Propan	Power Güç	Net Weight Net Ağırlık	Price Fiyat
SC4070G	Tek Sıra Ocak, Gazlı Single Row Cooker, Gas	400 x 700 x 290 mm	0,952 m ³ /h / 0,285 kg/h	9,6 kW	17 kg	
SC8070G	Tek Sıra Ocak, Gazlı Single Row Cooker, Gas	800 x 700 x 290 mm	1,904 m ³ /h / 0,570 kg/h	19,2 kW	24 kg	
SC1270G	Tek Sıra Ocak, Gazlı Single Row Cooker, Gas	1200 x 700 x 290 mm	2,850 m ³ /h / 0,850kg/h	28,8 kW	32 kg	

**OCAK, ELEKTRİKLİ
COOKER, ELECTRICAL****C4070E****C8070E****C1270E****TR**

- 2, 4 ve 6 ısı plakalı modelleri vardır.
- Üst seviye pişirme performansı ve homojen sıcaklık dağılımı sağlar.
- Plakaların her biri ayrı ayrı kademeli şalterle kontrol edilir.
- Her ısı plakasında aşırı ısı termiği mevcuttur. Bu termik sayesinde aşırı ısınma durumunda elektrikli keserek ısı plakasının zarar görmesini engeller.
- Her ısı plakasında 90-450 °C aralığında kontrol sağlayan 6 konumlu şalter vardır.

EN

- 2, 4 and 6 plate models are available.
- Advanced cooking performance and homogeneous heat distribution.
- Each plates are adjustable by multiple control switches.
- Each heating plate has own overheat thermic. In case of overheating, power cut will be in effect, automatically.
- Each cooker has own switch with 6 steps, controlling the heat between 90-450 °C.

PRODUCT CODE ÜRÜN KODU	PRODUCT NAME ÜRÜN ADI	Dimension (W x D x H) Ürün Ölçüsü (G x D x Y)	Power Güç	Voltage Gerilim	Net Weight Net Ağırlık	Price Fiyat
C4070E	Ocak, Yuvarlak, Elektrikli Cooker, Round, Electrical	400 x 700 x 290 mm	5,2 kW	400 V / 50 Hz	17 kg	
C8070E	Ocak, Yuvarlak, Elektrikli Cooker, Round, Electrical	800 x 700 x 290 mm	10,4 kW	400 V / 50 Hz	35 kg	
C1270E	Ocak, Yuvarlak, Elektrikli Cooker, Round, Electrical	1200 x 700 x 290 mm	15,6 kW	400 V / 50 Hz	47 kg	

KARE OCAK, ELEKTRİKLİ
SQUARE COOKER, ELECTRICAL

C1270ES



TR

- 6 ısı plakalı modeli vardır.
- Üst seviye pişirme performansı ve homojen sıcaklık dağılımı sağlar.
- Plakaların her biri ayrı ayrı kademeli şalterle kontrol edilir.
- Her ısı plakasında aşırı ısı termiği mevcuttur. Bu termik sayesinde aşırı ısınma durumunda elektrikli keserek ısı plakasının zarar görmesini engeller.
- Her ısı plakasında 90-450 °C aralığında kontrol sağlayan 6 konumlu şalter vardır.

EN

- 6 plates model is available..
- Advanced cooking performance and homogeneous heat distribution.
- Each plates are adjustable by multiple control switches.
- Each heating plate has own overheat thermic. In case of overheating, power cut will be in effect, automatically.
- Each cooker has its own switch with 6 steps, controlling the heat between 90-450 °C.

PRODUCT CODE ÜRÜN KODU	PRODUCT NAME ÜRÜN ADI	Dimension (W x D x H) Ürün Ölçüsü (G x D x Y)	Power Güç	Voltage Gerilim	Net Weight Net Ağırlık	Price Fiyat
C1270ES	Ocak, Kare, Elektrikli Cooker, Square, Electrical	1200 x 700 x 290 mm	15,6 kW	400 V / 50 Hz	60 kg	

**WOK OCAK, GAZLI
WOK COOKER, GAS****WC4070G****WC8070G****WC1270G****TR**

- 1, 2 ve 3 brülörlü modelleri vardır.
- Gaz muslukları emniyet ventillidir.
- Termokupl ve pilot ateşleme tertibatı vardır.
- Her bir brülör birbirinden bağımsız kontrol edilir.
- Kolay temizlenebilir, sağlam ve hijyeniktir.

EN

- 1, 2 and 3 burner models are available.
- Equipped with safety valves.
- Equipped with thermocouple and pilot ignition unit
- Each burner has own control button.
- Easy cleaning, durable and hygienic.

PRODUCT CODE ÜRÜN KODU	PRODUCT NAME ÜRÜN ADI	Dimension (W x D x H) Ürün Ölçüsü (G x D x Y)	Gas Consumption Natural Gas / Propane Gaz Sarfiyatı Doğalgaz / Propan	Power Güç	Net Weight Net Ağırlık	Price Fiyat
WC4070G	Wok Ocak, Gazlı Wok Cooker, Gas	400 x 700 x 290 mm	1,904 m ³ /h / 0,570 kg/h	10,5 kW	30 kg	
WC8070G	Wok Ocak, Gazlı Wok Cooker, Gas	800 x 700 x 290 mm	3,808 m ³ /h / 1,140 kg/h	21 kW	57 kg	
WC1270G	Wok Ocak, Gazlı Wok Cooker, Gas	1200 x 700 x 290 mm	5,712 m ³ /h / 1,710 kg/h	31,5 kW	83 kg	

KUZİNE, GAZLI
RANGE, GAS

CO8070G



TR

- Fırın içi GN 1/1 ölçüsündedir.
- Fırın içi kapasitesi 400 x 600 ölçüsünde tepsi alabilir.
- Termostatik gaz valfi kullanılmaktadır.
- Kolay temizlenebilir, sağlam ve hijyeniktir.
- Fırın içi kapasitesi 450 x 600 mm ölçüsünde tepsi alabilir.

EN

- Capacity of the oven is GN 1/1.
- 400 x 600 mm tray can be placed in the oven.
- Equipped with thermostatic gas valve.
- Easy cleaning, durable and hygienic.
- 450 x 600 mm tray or grid wire can be placed in the oven.



CO1270G



PRODUCT CODE ÜRÜN KODU	PRODUCT NAME ÜRÜN ADI	Dimension (W x D x H) Ürün Ölçüsü (G x D x Y)	Temperature Sıcaklık	Gas Consumption Natural Gas / Propane Gas Sarfiyatı Doğalgaz / Propan	Power Güç	Net Weight Net Ağırlık	Price Fiyat
CO8070G	Kuzine, Gazlı Range, Gas	800 x 700 x 900 mm	300 °C	3,800 m ³ /h / 1,184 kg/h	26+6 kW	90 kg	
CO1270G	Kuzine, Gazlı Range, Gas	1200 x 700 x 900 mm	300 °C	5,390 m ³ /h / 1,678 kg/h	39+6 kW	107 kg	

**KUZİNE, ELEKTRİKLİ
RANGE, ELECTRICAL****CO8070E****CO1270E****COF8070E****COF1270E****TR**

- Fırın içi GN 1/1 ölçüsündedir.
- Fırın içi kapasitesi 400 x 600 ölçüsünde tepsi alabilir.
- Kolay temizlenebilir, sağlam ve hijyeniktir.

EN

- Capacity of the oven is GN 1/1.
- 400 x 600 mm tray can be placed in the oven.
- Easy cleaning, durable and hygienic.

PRODUCT CODE ÜRÜN KODU	PRODUCT NAME ÜRÜN ADI	Dimension (W x D x H) Ürün Ölçüsü (G x D x Y)	Voltage Gerilim	Temperature Sıcaklık	Power Güç	Net Weight Net Ağırlık	Price Fiyat
CO8070E	Kuzine, Elektrikli Range, Electrical	800 x 700 x 900 mm	400 V	300 °C	10,4+5 kW	98 kg	
CO1270E	Kuzine, Elektrikli Range, Electrical	1200 x 700 x 900 mm	400 V	300 °C	15,6+5 kW	120 kg	
COF8070E	Kuzine, Fanlı, Elektrikli Range with Fan, Electrical	800 x 700 x 900 mm	400 V	300 °C	10,4+3,5 kW	98 kg	
COF1270E	Kuzine, Fanlı, Elektrikli Range with Fan, Electrical	1200 x 700 x 900 mm	400 V	300 °C	15,6+3,5 kW	120 kg	

**KUZİNE, GAZLI & ELEKTRİKLİ
RANGE, GAS & ELECTRICAL**

CO8070GE



CO1270GE



COF8070GE



COF1270GE



TR

- Fırın içi GN 1/1 ölçüsündedir.
- Fırın içi kapasitesi 400 x 600 ölçüsünde tepsi alabilir.
- Kolay temizlenebilir, sağlam ve hijyeniktir.

EN

- Capacity of the oven is GN 1/1.
- 400 x 600 mm tray can be placed in the oven.
- Easy cleaning, durable and hygienic.

PRODUCT CODE ÜRÜN KODU	PRODUCT NAME ÜRÜN ADI	Dimension (W x D x H) Ürün Ölçüsü (G x D x Y)	Voltage Gerilim	Temperature Sıcaklık	Gas Consumption Natural Gas / Propane Gaz Sarfiyatı Doğalgaz / Propan	Power Güç	Net Weight Net Ağırlık	Price Fiyat
CO8070GE	Kuzine, Gazlı & Elektrikli Range, Gas & Electrical	800 x 700 x 900 mm	400 V	300 °C	3,100 m ³ /h / 0,966 kg/h	26+5 kW	97 kg	
CO1270GE	Kuzine, Gazlı & Elektrikli Range, Gas & Electrical	1200 x 700 x 900 mm	400 V	300 °C	4,680 m ³ /h / 1,459 kg/h	39+5 kW	120 kg	
COF8070GE	Kuzine, Fanlı, Gazlı & Elektrikli Range with Fan, Gas & Electrical	800 x 700 x 900 mm	400 V	300 °C	2,960 m ³ /h / 0,925 kg/h	26+3,5 kW	97 kg	
COF1270GE	Kuzine, Fanlı, Gazlı & Elektrikli Range with Fan, Gas & Electrical	1200 x 700 x 900 mm	400 V	300 °C	4,540 m ³ /h / 1,415 kg/h	39+3,5 kW	120 kg	

PLEYT IZGARA, GAZLI
PLATE GRILL, GAS

GF4070G

GG4070G

GS8070G

TR

- Üst seviye pişirme performansı ve homojen sıcaklık dağılımı sağlamaktadır.
- 12 mm kalınlığında pleyt ızgara sayesinde tasarruflu pişirme sağlanmaktadır.
- Düz, oluklu ve yarı oluklu seçenekleriyle çeşitli pişirme olanakları sunmaktadır.
- Geniş yağ tahliye deliği sayesinde atık yağ kolayca yağ haznesine ulaşır.
- Gaz muslukları emniyet ventillidir.
- Termokupl ve pilot ateşleme tertibatı vardır.
- Manyetolu çakmağı vardır.

EN

- Best cooking performance and homogeneous heat distribution.
- Economic grilling with 12 mm plate thickness.
- Various grilling options with flat, grooved or semi grooved models.
- Waste oil easily reach the oil bowl due to its wide oil wasteway hole.
- Equipped with safety valves.
- Equipped with pilot and thermocouple.
- Equipped with piezoelectric ignition system for each burners.

PRODUCT CODE ÜRÜN KODU	PRODUCT NAME ÜRÜN ADI	Dimension (W x D x H) Ürün Ölçüsü (G x D x Y)	Gas Consumption Natural Gas / Propane Gaz Sarfiyatı Doğalgaz / Propan	Power Güç	Net Weight Net Ağırlık	Price Fiyat
GF4070G	Pleyt Izgara, Gazlı, Düz Plate Grill, Gas, Flat Top	400 x 700 x 290 mm	0,682 m ³ /h / 0,158 kg/h	5,2 kW	39 kg	
GG4070G	Pleyt Izgara, Gazlı, Oluklu Plate Grill, Gas, Grooved Top	400 x 700 x 290 mm	0,682 m ³ /h / 0,158 kg/h	5,2 kW	39 kg	
GF8070G	Pleyt Izgara, Gazlı, Düz Plate Grill, Gas, Flat Top	800 x 700 x 290 mm	1,364 m ³ /h / 0,316 kg/h	10,4 kW	73 kg	
GG8070G	Pleyt Izgara, Gazlı, Oluklu Plate Grill, Gas, Grooved Top	800 x 700 x 290 mm	1,364 m ³ /h / 0,316 kg/h	10,4 kW	73 kg	
GS8070G	Pleyt Izgara, Gazlı, Yarı Oluklu Plate Grill, Gas, Semi-Grooved Top	800 x 700 x 290 mm	1,364 m ³ /h / 0,316 kg/h	10,4 kW	73 kg	
GF9070G	Pleyt Izgara, Gazlı, Düz Plate Grill, Gas, Flat Top	900 x 700 x 290 mm	1,364 m ³ /h / 0,316 kg/h	10,4 kW	82 kg	
GG9070G	Pleyt Izgara, Gazlı, Oluklu Plate Grill, Gas, Grooved Top	900 x 700 x 290 mm	1,364 m ³ /h / 0,316 kg/h	10,4 kW	82 kg	
GS9070G	Pleyt Izgara, Gazlı, Yarı Oluklu Plate Grill, Gas, Semi-Grooved Top	900 x 700 x 290 mm	1,364 m ³ /h / 0,316 kg/h	10,4 kW	82 kg	
GF1070G	Pleyt Izgara, Gazlı, Düz Plate Grill, Gas, Flat Top	1000 x 700 x 290 mm	1,364 m ³ /h / 0,316 kg/h	10,4 kW	92 kg	
GG1070G	Pleyt Izgara, Gazlı, Oluklu Plate Grill, Gas, Grooved Top	1000 x 700 x 290 mm	1,364 m ³ /h / 0,316 kg/h	10,4 kW	92 kg	
GS1070G	Pleyt Izgara, Gazlı, Yarı Oluklu Plate Grill, Gas, Semi-Grooved Top	1000 x 700 x 290 mm	1,364 m ³ /h / 0,316 kg/h	10,4 kW	92 kg	
GF1270G	Pleyt Izgara, Gazlı, Düz Plate Grill, Gas, Flat Top	1200 x 700 x 290 mm	2,046 m ³ /h / 0,474 kg/h	15,6 kW	110 kg	
GG1270G	Pleyt Izgara, Gazlı, Oluklu Plate Grill, Gas, Grooved Top	1200 x 700 x 290 mm	2,046 m ³ /h / 0,474 kg/h	15,6 kW	110 kg	
GS1270G	Pleyt Izgara, Gazlı, Yarı Oluklu Plate Grill, Gas, Semi-Grooved Top	1200 x 700 x 290 mm	2,046 m ³ /h / 0,474 kg/h	15,6 kW	110 kg	

* Opsiyonel olarak 20 mm kalınlığında üretilebilir. Fiyat sormak için bizimle iletişime geçebilirsiniz.

* It can be produced 20 mm as an optional. You can ask for product price.

PLEYT IZGARA, GAZLI, KROM KAPLI, T
PLATE GRILL, GAS, CHROME COVERED, T

GF8070GC



GG8070GC



TR

- Pişirme yüzeyi sert krom kaplamadır.
- Üst seviye pişirme performansı ve homojen sıcaklık dağılımı sağlamaktadır.
- 12 mm kalınlığında pleyt ızgara sayesinde tasarruflı pişirme sağlanmaktadır.
- Düz, oluklu ve yarı oluklu seçenekleriyle çeşitli pişirme olanakları sunmaktadır.
- Geniş yağ tahliye deliği sayesinde atık yağ kolayca yağ haznesine ulaşır.
- Gaz muslukları emniyet ventillidir.
- Termokupl ve pilot ateşleme tertibatı vardır.
- Manyetolu çakmağı vardır.

EN

- Cooking surface is covered by hard chrome.
- Best cooking performance and homogeneous heat distribution.
- Economic grilling with 12 mm plate thickness.
- Various grilling options with flat, grooved or semi grooved models.
- Waste oil easily reach the oil bowl due to its wide oil wasteway hole.
- Equipped with safety valves.
- Equipped with pilot and thermocouple.
- Equipped with piezoelectric ignition system for each burners.

PRODUCT CODE ÜRÜN KODU	PRODUCT NAME ÜRÜN ADI	Dimension (W x D x H) Ürün Ölçüsü (G x D x Y)	Gas Consumption Natural Gas / Propane Gaz Sarfiyatı Doğalgaz / Propan	Power Güç	Net Weight Net Ağırlık	Price Fiyat
GF4070GC	Pleyt Izgara, Gazlı, Düz, Krom Kaplı, T Plate Grill, Gas, Flat Top, Chrome Covered, T	400 x 700 x 290 mm	0,682 m ³ /h / 0,158 kg/h	5,2 kW	39 kg	
GG4070GC	Pleyt Izgara, Gazlı, Oluklu, Krom Kaplı, T Plate Grill, Gas, Grooved Top, Chrome Covered, T	400 x 700 x 290 mm	0,682 m ³ /h / 0,158 kg/h	5,2 kW	39 kg	
GF8070GC	Pleyt Izgara, Gazlı, Düz, Krom Kaplı, T Plate Grill, Gas, Flat Top, Chrome Covered, T	800 x 700 x 290 mm	1,364 m ³ /h / 0,316 kg/h	10,4 kW	73 kg	
GG8070GC	Pleyt Izgara, Gazlı, Oluklu, Krom Kaplı, T Plate Grill, Gas, Grooved Top, Chrome Covered, T	800 x 700 x 290 mm	1,364 m ³ /h / 0,316 kg/h	10,4 kW	73 kg	
GS8070GC	Pleyt Izgara, Gazlı, Yarı Oluklu, Krom Kaplı, T Plate Grill, Gas, Semi-Grooved Top, Chrome Covered, T	800 x 700 x 290 mm	1,364 m ³ /h / 0,316 kg/h	10,4 kW	73 kg	
GF9070GC	Pleyt Izgara, Gazlı, Düz, Krom Kaplı, T Plate Grill, Gas, Flat Top, Chrome Covered, T	900 x 700 x 290 mm	1,364 m ³ /h / 0,316 kg/h	10,4 kW	82 kg	
GG9070GC	Pleyt Izgara, Gazlı, Oluklu, Krom Kaplı, T Plate Grill, Gas, Grooved Top, Chrome Covered, T	900 x 700 x 290 mm	1,364 m ³ /h / 0,316 kg/h	10,4 kW	82 kg	
GS9070GC	Pleyt Izgara, Gazlı, Yarı Oluklu, Krom Kaplı, T Plate Grill, Gas, Semi-Grooved Top, Chrome Covered, T	900 x 700 x 290 mm	1,364 m ³ /h / 0,316 kg/h	10,4 kW	82 kg	
GF1070GC	Pleyt Izgara, Gazlı, Düz, Krom Kaplı, T Plate Grill, Gas, Flat Top, Chrome Covered, T	1000 x 700 x 290 mm	1,364 m ³ /h / 0,316 kg/h	10,4 kW	92 kg	
GG1070GC	Pleyt Izgara, Gazlı, Oluklu, Krom Kaplı, T Plate Grill, Gas, Grooved Top, Chrome Covered, T	1000 x 700 x 290 mm	1,364 m ³ /h / 0,316 kg/h	10,4 kW	92 kg	
GS1070GC	Pleyt Izgara, Gazlı, Yarı Oluklu, Krom Kaplı, T Plate Grill, Gas, Semi-Grooved Top, Chrome Covered, T	1000 x 700 x 290 mm	1,364 m ³ /h / 0,316 kg/h	10,4 kW	92 kg	
GF1270GC	Pleyt Izgara, Gazlı, Düz, Krom Kaplı, T Plate Grill, Gas, Flat Top, Chrome Covered, T	1200 x 700 x 290 mm	2,046 m ³ /h / 0,474 kg/h	15,6 kW	110 kg	
GG1270GC	Pleyt Izgara, Gazlı, Oluklu, Krom Kaplı, T Plate Grill, Gas, Grooved Top, Chrome Covered, T	1200 x 700 x 290 mm	2,046 m ³ /h / 0,474 kg/h	15,6 kW	110 kg	
GS1270GC	Pleyt Izgara, Gazlı, Yarı Oluklu, Krom Kaplı, T Plate Grill, Gas, Semi-Grooved Top, Chrome Covered, T	1200 x 700 x 290 mm	2,046 m ³ /h / 0,474 kg/h	15,6 kW	110 kg	

PLEYT IZGARA, ELEKTRİKLİ
PLATE GRILL, ELECTRICAL

GF4070E

GG4070E

GS8070E

TR

- Üst seviye pişirme performansı ve homojen sıcaklık dağılımı sağlamaktadır.
- 12 mm kalınlığında pleyt izgara sayesinde tasarruflu pişirme sağlamaktadır.
- Düz, oluklu ve yarı oluklu seçenekleriyle çeşitli pişirme olanakları sunmaktadır.
- Geniş yağ tahliye deliği sayesinde atık yağ kolayca yağ haznesine ulaşır.
- Pişirme yüzeyinin sıcaklığı termostat kontrolü ile 50-300 °C arasında ayarlanabilmektedir.

EN

- Best cooking performance and homogeneous heat distribution.
- Economic grilling with 12 mm plate thickness.
- Various grilling options with flat, grooved or semi grooved models.
- Waste oil easily reach the oil bowl due to its wide oil wasteway hole.
- Cooktop temperature is adjustable between 50-300 °C with thermostat control.

PRODUCT CODE ÜRÜN KODU	PRODUCT NAME ÜRÜN ADI	Dimension (W x D x H) Ürün Ölçüsü (G x D x Y)	Voltage Gerilim	Temperature Sıcaklık	Power Güç	Net Weight Net Ağırlık	Price Fiyat
GF4070E	Pleyt Izgara, Elektrikli, Düz Plate Grill, Electrical, Flat Top	400 x 700 x 290 mm	400 V / 50 Hz	300 °C	4,8 kW	39 kg	
GG4070E	Pleyt Izgara, Elektrikli, Oluklu Plate Grill, Electrical, Grooved Top	400 x 700 x 290 mm	400 V / 50 Hz	300 °C	4,8 kW	39 kg	
GF8070E	Pleyt Izgara, Elektrikli, Düz Plate Grill, Electrical, Flat Top	800 x 700 x 290 mm	400 V / 50 Hz	300 °C	9,6 kW	71 kg	
GG8070E	Pleyt Izgara, Elektrikli, Oluklu Plate Grill, Electrical, Grooved Top	800 x 700 x 290 mm	400 V / 50 Hz	300 °C	9,6 kW	71 kg	
GS8070E	Pleyt Izgara, Elektrikli, Yarı Oluklu Plate Grill, Electrical, Semi-Grooved Top	800 x 700 x 290 mm	400 V / 50 Hz	300 °C	9,6 kW	71 kg	
GF9070E	Pleyt Izgara, Elektrikli, Düz Plate Grill, Electrical, Flat Top	900 x 700 x 290 mm	400 V / 50 Hz	300 °C	9,6 kW	79 kg	
GG9070E	Pleyt Izgara, Elektrikli, Oluklu Plate Grill, Electrical, Grooved Top	900 x 700 x 290 mm	400 V / 50 Hz	300 °C	9,6 kW	79 kg	
GS9070E	Pleyt Izgara, Elektrikli, Yarı Oluklu Plate Grill, Electrical, Semi-Grooved Top	900 x 700 x 290 mm	400 V / 50 Hz	300 °C	9,6 kW	79 kg	
GF1070E	Pleyt Izgara, Elektrikli, Düz Plate Grill, Electrical, Flat Top	1000 x 700 x 290 mm	400 V / 50 Hz	300 °C	9,6 kW	87 kg	
GG1070E	Pleyt Izgara, Elektrikli, Oluklu Plate Grill, Electrical, Grooved Top	1000 x 700 x 290 mm	400 V / 50 Hz	300 °C	9,6 kW	87 kg	
GS1070E	Pleyt Izgara, Elektrikli, Yarı Oluklu Plate Grill, Electrical, Semi-Grooved Top	1000 x 700 x 290 mm	400 V / 50 Hz	300 °C	9,6 kW	87 kg	
GF1270E	Pleyt Izgara, Elektrikli, Düz Plate Grill, Electrical, Flat Top	1200 x 700 x 290 mm	400 V / 50 Hz	300 °C	14,4 kW	103 kg	
GG1270E	Pleyt Izgara, Elektrikli, Oluklu Plate Grill, Electrical, Grooved Top	1200 x 700 x 290 mm	400 V / 50 Hz	300 °C	14,4 kW	103 kg	
GS1270E	Pleyt Izgara, Elektrikli, Yarı Oluklu Plate Grill, Electrical, Semi-Grooved Top	1200 x 700 x 290 mm	400 V / 50 Hz	300 °C	14,4 kW	103 kg	

PLEYT IZGARA, ELEKTRİKLİ, KROM KAPLI
PLATE GRILL, ELECTRICAL, CHROME COVERED⚡ **GF8070EC**KROM
CHROME⚡ **GG8070EC**

TR

- Pişirme yüzeyi sert krom kaplamadır.
- Üst seviye pişirme performansı ve homojen sıcaklık dağılımı sağlamaktadır.
- 12 mm kalınlığında pleyt ızgara sayesinde tasarruflu pişirme sağlamaktadır.
- Düz, oluklu ve yarı oluklu seçenekleriyle çeşitli pişirme olanakları sunmaktadır.
- Geniş yağ tahliye deliği sayesinde atık yağ kolayca yağ haznesine ulaşır.
- Pişirme yüzeyinin sıcaklığı termostat kontrolü ile 50-300 °C arasında ayarlanabilmektedir.

EN

- Cooking surface is covered by hard chrome.
- Best cooking performance and homogeneous heat distribution.
- Economic grilling with 12mm plate thickness.
- Various grilling options with flat, grooved or semi grooved models.
- Waste oil easily reach the oil bowl due to its wide oil wasteway hole.
- Cooktop temperature is adjustable between 50-300 °C with thermostat control.

PRODUCT CODE ÜRÜN KODU	PRODUCT NAME ÜRÜN ADI	Dimension (W x D x H) Ürün Ölçüsü (G x D x Y)	Voltage Gerilim	Temperature Sıcaklık	Power Güç	Net Weight Net Ağırlık	Price Fiyat
GF4070EC	Pleyt Izgara, Elektrikli, Düz, Krom Kaplı Plate Grill, Electrical, Flat Top, Chrome Covered	400 x 700 x 290 mm	400 V / 50 Hz	300 °C	4,8 kW	39 kg	
GG4070EC	Pleyt Izgara, Elektrikli, Oluklu, Krom Kaplı Plate Grill, Electrical, Grooved Top, Chrome Covered	400 x 700 x 290 mm	400 V / 50 Hz	300 °C	4,8 kW	39 kg	
GF8070EC	Pleyt Izgara, Elektrikli, Düz, Krom Kaplı Plate Grill, Electrical, Flat Top, Chrome Covered	800 x 700 x 290 mm	400 V / 50 Hz	300 °C	9,6 kW	71 kg	
GG8070EC	Pleyt Izgara, Elektrikli, Oluklu, Krom Kaplı Plate Grill, Electrical, Grooved Top, Chrome Covered	800 x 700 x 290 mm	400 V / 50 Hz	300 °C	9,6 kW	71 kg	
GS8070EC	Pleyt Izgara, Elektrikli, Yarı Oluklu, Krom Kaplı Plate Grill, Electrical, Semi-Grooved Top, Chrome Covered	800 x 700 x 290 mm	400 V / 50 Hz	300 °C	9,6 kW	71 kg	
GF9070EC	Pleyt Izgara, Elektrikli, Düz, Krom Kaplı Plate Grill, Electrical, Flat Top, Chrome Covered	900 x 700 x 290 mm	400 V / 50 Hz	300 °C	9,6 kW	79 kg	
GG9070EC	Pleyt Izgara, Elektrikli, Oluklu, Krom Kaplı Plate Grill, Electrical, Grooved Top, Chrome Covered	900 x 700 x 290 mm	400 V / 50 Hz	300 °C	9,6 kW	79 kg	
GS9070EC	Pleyt Izgara, Elektrikli, Yarı Oluklu, Krom Kaplı Plate Grill, Electrical, Semi-Grooved Top, Chrome Covered	900 x 700 x 290 mm	400 V / 50 Hz	300 °C	9,6 kW	79 kg	
GF1070EC	Pleyt Izgara, Elektrikli, Düz, Krom Kaplı Plate Grill, Electrical, Flat Top, Chrome Covered	1000 x 700 x 290 mm	400 V / 50 Hz	300 °C	9,6 kW	87 kg	
GG1070EC	Pleyt Izgara, Elektrikli, Oluklu, Krom Kaplı Plate Grill, Electrical, Grooved Top, Chrome Covered	1000 x 700 x 290 mm	400 V / 50 Hz	300 °C	9,6 kW	87 kg	
GS1070EC	Pleyt Izgara, Elektrikli, Yarı Oluklu, Krom Kaplı Plate Grill, Electrical, Semi-Grooved Top, Chrome Covered	1000 x 700 x 290 mm	400 V / 50 Hz	300 °C	9,6 kW	87 kg	
GF1270EC	Pleyt Izgara, Elektrikli, Düz, Krom Kaplı Plate Grill, Electrical, Flat Top, Chrome Covered	1200 x 700 x 290 mm	400 V / 50 Hz	300 °C	14,4 kW	103 kg	
GG1270EC	Pleyt Izgara, Elektrikli, Oluklu, Krom Kaplı Plate Grill, Electrical, Grooved Top, Chrome Covered	1200 x 700 x 290 mm	400 V / 50 Hz	300 °C	14,4 kW	103 kg	
GS1270EC	Pleyt Izgara, Elektrikli, Yarı Oluklu, Krom Kaplı Plate Grill, Electrical, Semi-Grooved Top, Chrome Covered	1200 x 700 x 290 mm	400 V / 50 Hz	300 °C	14,4 kW	103 kg	

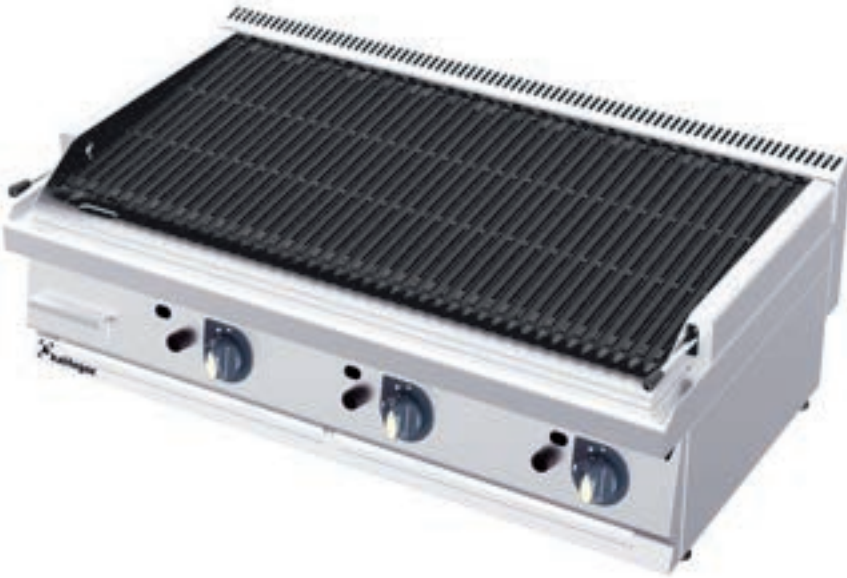
**LAVTAŞ IZGARA, GAZLI
LAV STONE GRILL, GAS****LG4070G****LG8070G****LG1270G****TR**

- Pişirme yüzeyi sac ızgara veya döküm olarak tercih edilebilir.
- 1, 2 ve 3 brülörlü modelleri vardır.
- Gaz muslukları emniyet ventillidir.
- Termokupl ve pilot ateşleme tertibatı vardır.
- Manyetolu çakmağı vardır.
- Özel tasarım v tipi ızgara ve döküm sayesinde atık yağ kolayca ön tarafta yer alan hazneye aktarılmaktadır.
- Yükseklik ayarı yapılabilen ızgara sayesinde pişirme hızı ve şiddeti ayarlanabilir.

EN

- Cooking surface can be preferred as stainless steel grill or cast.
- 1, 2 and 3 burner models are available.
- Equipped with safety valves.
- Equipped with thermocouple and pilot ignition unit
- Equipped piezoelectric ignition system for each burners.
- Special design v shaped stainless steel grill and cast prevents oil dripping to the burners.
- Distance from burner and back part of cast iron grills are adjustable by front handled lever.

PRODUCT CODE ÜRÜN KODU	PRODUCT NAME ÜRÜN ADI	Dimension (W x D x H) Ürün Ölçüsü (G x D x Y)	Gas Consumption Natural Gas / Propane Gaz Sarfıyatı Doğalgaz / Propan	Power Güç	Net Weight Net Ağırlık	Price Fiyat
LG4070G	Lavtaş Izgara, Gazlı Lav Stone Grill, Gas	400 x 700 x 290 mm	0,952 m ³ /h / 0,285 kg/h	9 kW	51 kg	
LG8070G	Lavtaş Izgara, Gazlı Lav Stone Grill, Gas	800 x 700 x 290 mm	1,904 m ³ /h / 0,570 kg/h	18 kW	85 kg	
LG1270G	Lavtaş Izgara, Gazlı Lav Stone Grill, Gas	1200 x 700 x 290 mm	2,850 m ³ /h / 0,850 kg/h	27 kW	136 kg	

SULU IZGARA, GAZLI
VAPOUR GRILL, GAS

VG4070G



VG8070G



TR

- 1, 2 ve 3 brülörlü modelleri vardır.
- Gaz muslukları emniyet ventillidir.
- Termokupl ve pilot ateşleme tertibatı vardır.
- Manyetolu çakmağı vardır.
- Özel tasarım ızgara ile pişirme esnasında oluşan atık yağ kolayca su dolu hazneye aktarılmaktadır.
- Bu şekilde ortaya çıkan duman ve koku minimum seviyede tutulur.

EN

- 1, 2 and 3 burner models.
- Equipped with safety valves.
- Equipped with thermocouple and pilot ignition unit
- Equipped piezoelectric ignition system for each burners.
- Special design v shape cast iron grills easliy transfer the grease to water tank.
- Fats easily collected at the water filled tray and minimize odour and smoke.



VG1270G



PRODUCT CODE ÜRÜN KODU	PRODUCT NAME ÜRÜN ADI	Dimension (W x D x H) Ürün Ölçüsü (G x D x Y)	Gas Consumption Natural Gas / Propane Gaz Sarfiyatı Doğalgaz / Propan	Power Güç	Net Weight Net Ağırlık	Price Fiyat
VG4070G	Sulu Izgara, Gazlı Vapour Grill, Gas	400 x 700 x 290 mm	0,726 m ³ /h / 0,230 kg/h	6,9 kW	47 kg	
VG8070G	Sulu Izgara, Gazlı Vapour Grill, Gas	800 x 700 x 290 mm	1,452 m ³ /h / 0,418 kg/h	13,8 kW	76 kg	
VG1270G	Sulu Izgara, Gazlı Vapour Grill, Gas	1200 x 700 x 290 mm	2,178 m ³ /h / 0,627 kg/h	20,7 kW	116 kg	

**SULU IZGARA, GAZLI, T MODEL
VAPOUR GRILL, GAS, T MODEL****VGOS4070GT****VGOS8070GT****VGOS1270GT****TR**

- Paslanmaz çelik gövde.
- Doğalgaz ya da LPG uyumlu.
- Kolayca kaldırılabilen mil ızgaralar.
- Geniş su çekmecesinin sayesinde nemlendirerek pişirme.
- Emniyet ventilli gaz musluğu.
- Özel tasarım ızgara sayesinde pişirme esnasında oluşan atık yağ kolayca su dolu hazneye aktarılmaktadır.
- Bu şekilde ortaya çıkan duman ve koku minimum seviyede tutulur.

EN

- Stainless steel body.
- Natural gas or LPG compatible.
- Easy to remove spindle grills.
- Moist cooking due to water drawer.
- Equipped with safety valves.
- Special design grills easily transfer the grease to water tank.
- Fats easily collected at the water filled tray and minimize odour and smoke.

PRODUCT CODE ÜRÜN KODU	PRODUCT NAME ÜRÜN ADI	Dimension (W x D x H) Ürün Ölçüsü (G x D x Y)	Gas Consumption Natural Gas / Propane Gaz Sarfiyatı Doğalgaz / Propan	Power Güç	Net Weight Net Ağırlık	Price Fiyat
VGOS4070GT	Sulu Izgara, Gazlı, T Model Vapour Grill, Gas, T Model	400 x 700 x 900 mm	1,37 m ³ /h / 1,01 kg/h	11 kW	45 kg	
VGOS8070GT	Sulu Izgara, Gazlı, T Model Vapour Grill, Gas, T Model	800 x 700 x 900 mm	2,80 m ³ /h / 2,07 kg/h	22 Kw	110 kg	
VGOS1270GT	Sulu Izgara, Gazlı, T Model Vapour Grill, Gas, T Model	1200 x 700 x 900 mm	3,82 m ³ /h / 2,82 kg/h	33 kW	150 kg	

SULU IZGARA, GAZLI, T MODEL, PLEYT MODÜLLÜ VAPOUR GRILL, GAS, T MODEL, WITH PLATE MODULE

TR

- Paslanmaz çelik gövde
- Doğalgaz ya da LPG uyumlu
- Kolayca kaldırılabilen mil ızgaralar
- Geniş su çekmecesi sayesinde nemlendirerek pişirme
- Emniyet ventilli gaz musluğu
- Özel tasarım ızgara sayesinde pişirme esnasında oluşan atık yağ kolayca su dolu hazneye aktarılmaktadır
- Bu şekilde ortaya çıkan duman ve koku minimum seviyede tutulur
- Opsiyonel olarak pleyt ızgarayla da kullanılabilir

EN

- Stainless steel body
- Natural gas or LPG compatible
- Easy to remove spindle grills
- Moist cooking due to water drawer
- Equipped with safety valves
- Special design grills easily transfer the grease to water tank
- Fats easily collected at the water filled tray and minimize odour and smoke
- Optionally available with plate grill



VGOS8070GTP



VGOS1270GTP



PRODUCT CODE ÜRÜN KODU	PRODUCT NAME ÜRÜN ADI	Dimension (W x D x H) Ürün Ölçüsü (G x D x Y)	Gas Consumption Natural Gas / Propane Gaz Sarfiyatı Doğalgaz / Propan	Power Güç	Net Weight Net Ağırlık	Price Fiyat
VGOS8070GTP	Sulu Izgara, Gazlı, T Model, Pleyt Modüllü Vapour Grill, Gas, T Model with Plate Module	800 x 700 x 900 mm	2,80 m ³ /h / 2,07 kg/h	22 Kw	95 kg	
VGOS1270GTP	Sulu Izgara, Gazlı, T Model, Pleyt Modüllü Vapour Grill, Gas, T Model with Plate Module	1200 x 700 x 900 mm	3,82 m ³ /h / 2,82 kg/h	33 kW	128 kg	

**BENMARI, ELEKTRİKLİ
BAIN-MARIE, ELECTRICAL****BM4070E****TR**

- Sıcak buhar sayesinde yiyeceklerin servis sıcaklığında bekletilmesini sağlar.
- Paslanmaz çelik gövde ve su haznesi.
- Tüp rezistans kullanılmaktadır.
- Termostatik kontrol.
- Su dolumu manuel olarak yapılabilir.
- Su boşaltma musluğu bulunmaktadır.
- Hazne kapasitesi 3 x GN ¼ 150
- Kullanım rahatlığı sağlayan ergonomik dizayna sahiptir.
- Profesyonel kullanım için uygundur.
- Kolay temizlenebilir ve hijyeniktir.

EN

- It keeps foods at the service temperature through hot steam.
- Stainless steel body and water tank.
- Tube resistance is used.
- Thermostatic control.
- Water filling can be done manually.
- There is a drain pipe.
- Bowl capacity 3 x GN ¼ 150
- It has an ergonomic design that provides ease of use.
- Suitable for professional use.
- Easy to clean and hygienic.

PRODUCT CODE ÜRÜN KODU	PRODUCT NAME ÜRÜN ADI	Capacity Kapasite	Voltage Gerilim	Temperature Sıcaklık	Power Güç	Dimension (W x D x H) Ürün Ölçüsü (G x D x Y)	Net Weight Net Ağırlık	Price Fiyat
BM4070E	Benmari, Elektrikli Bain-Marie, Electrical	GN 1/1 150	230 V	110 °C	1,00 kW	400 x 700 x 290 mm	14 kg	

NÖTR TEZGAH
NEUTRAL COUNTER

N4070



N8070



N1270



TR

- Paslanmaz çelikten imal edilmiştir.
- Pişirme öncesi her türlü hazırlık için kullanılabilir.
- Kolay temizlenebilir, sağlam ve hijyeniktir.

EN

- It's made of stainless steel.
- It can be used for any preparation before cooking.
- Easy cleaning, durable and hygienic.

PRODUCT CODE ÜRÜN KODU	PRODUCT NAME ÜRÜN ADI	Dimension (W x D x H) Ürün Ölçüsü (G x D x Y)	Net Weight Net Ağırlık	Price Fiyat
N4070	Nötr Tezgah Neutral Counter	400 x 700 x 290 mm	11 kg	
N8070	Nötr Tezgah Neutral Counter	800 x 700 x 290 mm	19 kg	
N1270	Nötr Tezgah Neutral Counter	1200 x 700 x 290 mm	26 kg	

SNACK SERİ STAND
SNACK SERIE STAND**CS4070****OS4070****DS4070****CS8070****OS8070****DS8070****CS1270****OS1270**

PRODUCT CODE ÜRÜN KODU	PRODUCT NAME ÜRÜN ADI	Dimension (W x D x H) Ürün Ölçüsü (G x D x Y)	Net Weight Net Ağırlık	Price Fiyat
CS4070	Stand, Kapaklı / Stand, Cabinet	400 x 700 x 610 mm	14 kg	
CS8070	Stand, Kapaklı / Stand, Cabinet	800 x 700 x 610 mm	23 kg	
CS1270	Stand, Kapaklı / Stand, Cabinet	1200 x 700 x 610 mm	35 kg	
OS4070	Stand, Kapaksız / Stand, Coverless	400 x 700 x 610 mm	11 kg	
OS8070	Stand, Kapaksız / Stand, Coverless	800 x 700 x 610 mm	17 kg	
OS1270	Stand, Kapaksız / Stand, Coverless	1200 x 700 x 610 mm	26 kg	
DS4070	Stand, Çekmeceli / Stand, Drawer	400 x 700 x 610 mm	19 kg	
DS8070	Stand, Çekmeceli / Stand, Drawer	800 x 700 x 610 mm	33 kg	

900 SERİSİ

900 SERIE



Ocak, Gazlı / Cooker, Gas

Ocak, Mono Blok, Gazlı / Cooker, Mono Block, Gas

Kuzine, Gazlı / Range, Gas

Kuzine, Gazlı & Elektrikli / Range, Gas & Electrical

Pleyt Izgara, Gazlı / Plate Grill, Gas

Pleyt Izgara, Mono Blok, Gazlı / Plate Grill, Mono Block, Gas

Pleyt Izgara, Elektrikli / Plate Grill, Electrical

Pleyt Izgara, Mono Blok, Elektrikli / Plate Grill, Mono Block, Electrical

Lavtaş Izgara, Mono Blok, Gazlı / Lav Stone Grill, Mono Block, Gas

Sulu Izgara, Mono Blok, Gazlı, T Model / Vapour Grill, Mono Block, Gas, T Model

Fritöz, Mono Blok, Elektrikli / Fryer, Mono Block, Electrical

Stand, Snack Seri / Stand, Snack Serie

OCAK, GAZLI
COOKER, GAS









C4090G

C8090G

C1290G

TR

- Paslanmaz çelik gövde
- 2, 4 ve 6 brülörlü modelleri vardır.
- Gaz muslukları emniyet ventillidir.
- Termokupl ve pilot ateşleme tertibatı vardır.
- Her bir brülör birbirinden bağımsız kontrol edilir.
- Kolay temizlenebilir, sağlam ve hijyeniktir.

PRODUCT CODE ÜRÜN KODU	PRODUCT NAME ÜRÜN ADI	Dimension (W x D x H) Ürün Ölçüsü (G x D x Y)	Gas Consumption Natural Gas / Propane Gaz Sarfiyatı Doğalgaz / Propan	Power Güç	Net Weight Net Ağırlık	Price Fiyat	Lineup Dizilim
C4090G	Ocak, Gazlı Cooker, Gas	400 x 900 x 290	2,015 m ³ /h / 0,517 kg/h	19 kW	43 kg		
C8090G	Ocak, Gazlı Cooker, Gas	800 x 900 x 290	4,030 m ³ /h / 1,034 kg/h	38 kW	66 kg		
C1290G	Ocak, Gazlı Cooker, Gas	1200 x 900 x 290	6,045 m ³ /h / 1,551 kg/h	57 kW	90 kg		
LC4090G	Ocak, Gazlı Cooker, Gas	400 x 900 x 290	1,636 m ³ /h / 0,410 kg/h	16 kW	38 kg		
LC8090G	Ocak, Gazlı Cooker, Gas	800 x 900 x 290	3,272 m ³ /h / 0,820 kg/h	32 kW	61 kg		
LC1290G	Ocak, Gazlı Cooker, Gas	1200 x 900 x 290	4,908 m ³ /h / 1,230 kg/h	48 kW	85 kg		
BC4090G	Ocak, Gazlı Cooker, Gas	400 x 900 x 290	2,394 m ³ /h / 0,624 kg/h	22 kW	48 kg		
BC8090G	Ocak, Gazlı Cooker, Gas	800 x 900 x 290	4,788 m ³ /h / 1,248 kg/h	44 kW	71 kg		
BC1290G	Ocak, Gazlı Cooker, Gas	1200 x 900 x 290	7,182 m ³ /h / 1,872 kg/h	66 kW	95 kg		

**OCAK, MONO BLOK, GAZLI
COOKER, MONO BLOCK, GAS**



CCS4090G



CCS8090G



CCS1290G



EN

- Stainless steel body
- 2, 4 and 6 burner models are available.
- Equipped with safety valves.
- Equipped with thermocouple and pilot ignition unit
- Each burner has own control button
- Easy cleaning, durable hygienic.

PRODUCT CODE ÜRÜN KODU	PRODUCT NAME ÜRÜN ADI	Dimension (W x D x H) Ürün Ölçüsü (G x D x Y)	Gas Consumption Natural Gas / Propane Gaz Sarfiyatı Doğalgaz / Propan	Power Güç	Net Weight Net Ağırlık	Price Fiyat	Lineup Dizilim
CCS4090G	Ocak, Mono Blok, Gazlı Cooker, Mono Block, Gas	400 x 900 x 900	2,015 m ³ /h / 0,517 kg/h	19 kW	52 kg		
CCS8090G	Ocak, Mono Blok, Gazlı Cooker, Mono Block, Gas	800 x 900 x 900	4,030 m ³ /h / 1,034 kg/h	38 kW	75 kg		
CCS1290G	Ocak, Mono Blok, Gazlı Cooker, Mono Block, Gas	1200 x 900 x 900	6,045 m ³ /h / 1,551 kg/h	57 kW	100 kg		
LCCS4090G	Ocak, Mono Blok, Gazlı Cooker, Mono Block, Gas	400 x 900 x 900	1,636 m ³ /h / 0,410 kg/h	16 kW	47 kg		
LCCS8090G	Ocak, Mono Blok, Gazlı Cooker, Mono Block, Gas	800 x 900 x 900	3,272 m ³ /h / 0,820 kg/h	32 kW	70 kg		
LCCS1290G	Ocak, Mono Blok, Gazlı Cooker, Mono Block, Gas	1200 x 900 x 900	4,908 m ³ /h / 1,230 kg/h	48 kW	94 kg		
BCCS4090G	Ocak, Mono Blok, Gazlı Cooker, Mono Block, Gas	400 x 900 x 900	2,394 m ³ /h / 0,624 kg/h	22 kW	57 kg		
BCCS8090G	Ocak, Mono Blok, Gazlı Cooker, Mono Block, Gas	800 x 900 x 900	4,788 m ³ /h / 1,248 kg/h	44 kW	80 kg		
BCCS1290G	Ocak, Mono Blok, Gazlı Cooker, Mono Block, Gas	1200 x 900 x 900	7,182 m ³ /h / 1,872 kg/h	66 kW	104 kg		

**KUZİNE, GAZLI
RANGE, GAS****CO8090G****TR**

- Paslanmaz çelik gövde.
- Fırın bölümünde Termostatik gaz valfi kullanılmaktadır.
- Thermokupl ve pilot ateşleme teribatıbatı vardır.
- Her bir brülör birbirinden bağımsız kontrol edilir.
- Kolay temizlenebilir, sağlam ve hijyeniktir.

EN

- Stainless steel body
- Equipped with thermocouple and pilot ignition unit
- Equipped with thermostatic gas valve to control oven unit.
- Each burner has own control button.
- Easy cleaning, durable and hygienic.

**CO1290G**

PRODUCT CODE ÜRÜN KODU	PRODUCT NAME ÜRÜN ADI	Dimension (W x D x H) Ürün Ölçüsü (G x D x Y)	Gas Consumption Natural Gas / Propane Gaz Sarfiyatı Doğalgaz / Propan	Power Güç	Net Weight Net Ağırlık	Price Fiyat
CO8090G	Kuzine, Gazlı Range, Gas	800 x 900 x 900 mm	4,716 m ³ /h / 1,232 kg/h	38+6 kW	135 kg	
CO1290G	Kuzine, Gazlı Range, Gas	1200 x 900 x 900 mm	6,731 m ³ /h / 1,749 kg/h	57+6 kW	160 kg	

KUZİNE, GAZLI & ELEKTRİKLİ
RANGE, GAS & ELECTRICAL

TR

- Paslanmaz çelik gövde.
- Her bir brülör birbirinden bağımsız kontrol edilir.
- Kolay temizlenebilir, sağlam ve hijyeniktir.
- Alt kısmında elektrikli fırın bölümü bulunmaktadır.
- Isı kontrolü sağlayan termostat mevcuttur.
- Fırının içi GN 2/1 ölçüye uygundur.
- 640 x 600 mm ölçüsünde tepsi veya ızgara tel alabilir.

EN

- Stainless steel body
- Each burner has own control button.
- Easy cleaning, durable and hygienic.
- An electric oven section at the lower part.
- A thermostat providing temperature control.
- The inside of the oven is suitable for GN 2/1 size.
- 640 x 600 mm tray or grid wire can be placed at the oven.



CO8090GE



CO1290GE



PRODUCT CODE ÜRÜN KODU	PRODUCT NAME ÜRÜN ADI	Dimension (W x D x H) Ürün Ölçüsü (G x D x Y)	Voltage Gerilim	Temperature Sıcaklık	Gas Consumption Natural Gas / Propane Gaz Sarfiyatı Doğalgaz / Propan	Power Güç	Net Weight Net Ağırlık	Price Fiyat
CO8090GE	Kuzine, Gazlı & Elektrikli Range, Gas & Electrical	800 x 900 x 900 mm	400 V	300°C	4,030m ³ /h / 1,034 kg/h	38+6,5 kW	140 kg	
CO1290GE	Kuzine, Gazlı & Elektrikli Range, Gas & Electrical	1200 x 900 x 900 mm	400 V	300°C	6,045m ³ /h / 1,551 kg/h	57+6,5 kW	165 kg	

PLEYT IZGARA, GAZLI
PLATE GRILL, GAS

GF4090G

GG8090G

GS1290G

TR

- Paslanmaz çelik gövde
- Üst seviye pişirme performansı ve homojen sıcaklık dağılımı sağlar.
- 12mm kalınlığında pleyt ızgara sayesinde tasarruflu pişirme sağlar.
- Düz, oluklu ve yarı oluklu seçenekleriyle çeşitli pişirme olanakları sunar.
- Geniş yağ tahliye deliği sayesinde atık yağ kolayca yağ haznesine ulaşır.
- Gaz muslukları emniyet ventillidir.
- Termokupl ve pilot ateşleme tertibatı vardır.
- Manyetolu çakmağı vardır.

EN

- Stainless steel body.
- Best cooking performance and homogeneous heat distribution.
- Economic griling options with flat, grooved or semi grooved models.
- Waste oil easily reach the oil wasteway hole.
- Equipped with pilot and thermocouple.
- Equipped with piezoelectric ignition system for each burners.

PRODUCT CODE ÜRÜN KODU	PRODUCT NAME ÜRÜN ADI	Dimension (W x D x H) Ürün Ölçüsü (G x D x Y)	Gas Consumption Natural Gas / Propane Gaz Sarfiyatı Doğalgaz / Propan	Power Güç	Net Weight Net Ağırlık	Price Fiyat
GF4090G	Pleyt Izgara, Gazlı, Düz Plate Grill, Gas, Flat Top	400 x 900 x 290 mm	0,92 m ³ /h / 0,213 kg/h	7 kW	45 kg	
GF8090G	Pleyt Izgara, Gazlı, Düz Plate Grill, Gas, Flat Top	800 x 900 x 290 mm	1,84 m ³ /h / 0,426 kg/h	14 kW	85 kg	
GF1290G	Pleyt Izgara, Gazlı, Düz Plate Grill, Gas, Flat Top	1200 x 900 x 290 mm	2,76 m ³ /h / 0,639 kg/h	21 kW	125 kg	
GG4090G	Pleyt Izgara, Gazlı, Oluklu Plate Grill, Gas, Grooved Top	400 x 900 x 290 mm	0,92 m ³ /h / 0,213 kg/h	7 kW	45 kg	
GG8090G	Pleyt Izgara, Gazlı, Oluklu Plate Grill, Gas, Grooved Top	800 x 900 x 290 mm	1,84 m ³ /h / 0,426 kg/h	14 kW	85 kg	
GG1290G	Pleyt Izgara, Gazlı, Oluklu Plate Grill, Gas, Grooved Top	1200 x 900 x 290 mm	2,76 m ³ /h / 0,639 kg/h	21 kW	125 kg	
GS8090G	Pleyt Izgara, Gazlı, Yarı Oluklu Plate Grill, Gas, Semi-Grooved Top	800 x 900 x 290 mm	1,84 m ³ /h / 0,426 kg/h	14 kW	85 kg	
GS1290G	Pleyt Izgara, Gazlı, Yarı Oluklu Plate Grill, Gas, Semi-Grooved Top	1200 x 900 x 290 mm	2,76 m ³ /h / 0,639 kg/h	21 kW	125 kg	

PLEYT IZGARA, MONO BLOK, GAZLI
PLATE GRILL, MONO BLOCK, GAS**GFCS4090G****GGCS8090G****TR**

- Paslanmaz çelik gövde
- Üst seviye pişirme performansı ve homojen sıcaklık dağılımı sağlar.
- 12mm kalınlığında pleyt ızgara sayesinde tasarruflu pişirme sağlar.
- Düz, oluklu ve yarı oluklu seçenekleriyle çeşitli pişirme olanakları sunar.
- Geniş yağ tahliye deliği sayesinde atık yağ kolayca yağ haznesine ulaşır.
- Gaz muslukları emniyet ventillidir.
- Termokupl ve pilot ateşleme tertibatı vardır.
- Manyetolu çakmağı vardır.

EN

- Stainless steel body.
- Best cooking performance and homogeneous heat distribution.
- Economic grilling options with flat, grooved or semi grooved models.
- Waste oil easily reach the oil wasteway hole.
- Equipped with pilot and thermocouple.
- Equipped with piezoelectric ignition system for each burners.

**GSCS1290G**

PRODUCT CODE ÜRÜN KODU	PRODUCT NAME ÜRÜN ADI	Dimension (W x D x H) ÜRÜN ÖLÇÜSÜ (G x D x Y)	Gas Consumption Natural Gas / Propane Gaz Sarfiyatı Doğalgaz / Propan	Power Güç	Net Weight Net Ağırlık	Price Fiyat
GFCS4090G	Pleyt Izgara, Mono Blok, Gazlı, Düz Plate Grill, Mono Block, Gas, Flat Top	400 x 900 x 900 mm	0,92 m ³ /h / 0,213 kg/h	7 kW	80 kg	
GFCS8090G	Pleyt Izgara, Mono Blok, Gazlı, Düz Plate Grill, Mono Block, Gas, Flat Top	800 x 900 x 900 mm	1,84 m ³ /h / 0,426 kg/h	14 kW	115 kg	
GFCS1290G	Pleyt Izgara, Mono Blok, Gazlı, Düz Plate Grill, Mono Block, Gas, Flat Top	1200 x 900 x 900 mm	2,76 m ³ /h / 0,639 kg/h	21 kW	175 kg	
GGCS4090G	Pleyt Izgara, Mono Blok, Gazlı, Oluklu Plate Grill, Mono Block, Gas, Grooved Top	400 x 900 x 900 mm	0,92 m ³ /h / 0,213 kg/h	7 kW	80 kg	
GGCS8090G	Pleyt Izgara, Mono Blok, Gazlı, Oluklu Plate Grill, Mono Block, Gas, Grooved Top	800 x 900 x 900 mm	1,84 m ³ /h / 0,426 kg/h	14 kW	115 kg	
GGCS1290G	Pleyt Izgara, Mono Blok, Gazlı, Oluklu Plate Grill, Mono Block, Gas, Grooved Top	1200 x 900 x 900 mm	2,76 m ³ /h / 0,639 kg/h	21 kW	175 kg	
GSCS8090G	Pleyt Izgara, Mono Blok, Gazlı, Yarı Oluklu Plate Grill, Mono Block, Gas, Semi-Grooved Top	800 x 900 x 900 mm	1,84 m ³ /h / 0,426 kg/h	14 kW	115 kg	
GSCS1290G	Pleyt Izgara, Mono Blok, Gazlı, Yarı Oluklu Plate Grill, Mono Block, Gas, Semi-Grooved Top	1200 x 900 x 900 mm	2,76 m ³ /h / 0,639 kg/h	21 kW	175 kg	

PLEYT IZGARA, ELEKTRİKLİ
PLATE GRILL, ELECTRICAL

GF4090E

GG8090E

GS1290E

TR

- Paslanmaz çelik gövde
- Üst seviye pişirme performansı ve homojen sıcaklık dağılımı sağlar.
- 12mm kalınlığında pleyt ızgara sayesinde tasarruflu pişirme sağlar.
- Düz, oluklu ve yarı oluklu seçenekleriyle çeşitli pişirme olanakları sunar.
- Geniş yağ tahliye deliği sayesinde atık yağ kolayca yağ haznesine ulaşır.
- Pişirme yüzeyinin sıcaklığı termostat kontrolü ile 50-300 C arasında ayarlanabilmektedir.

PRODUCT CODE ÜRÜN KODU	PRODUCT NAME ÜRÜN ADI	Dimension (W x D x H) Ürün Ölçüsü(G x D x Y)	Voltage Gerilim	Temperature Sıcaklık	Power Güç	Net Weight Net Ağırlık	Price Fiyat
GF4090E	Pleyt Izgara, Elektrikli, Düz Plate Grill, Electrical, Flat Top	400 x 900 x 900 mm	400 V / 50 Hz	300 °C	5,1 kW	45 kg	
GF8090E	Pleyt Izgara, Elektrikli, Düz Plate Grill, Electrical, Flat Top	800 x 900 x 900 mm	400 V / 50 Hz	300 °C	10,2 kW	85 kg	
GF1290E	Pleyt Izgara, Elektrikli, Düz Plate Grill, Electrical, Flat Top	1200 x 900 x 900 mm	400 V / 50 Hz	300 °C	15,3 kW	125 kg	
GG4090E	Pleyt Izgara, Elektrikli, Oluklu Plate Grill, Electrical, Grooved Top	400 x 900 x 900 mm	400 V / 50 Hz	300 °C	5,1 kW	45 kg	
GG8090E	Pleyt Izgara, Elektrikli, Oluklu Plate Grill, Electrical, Grooved Top	800 x 900 x 900 mm	400 V / 50 Hz	300 °C	10,2 kW	85 kg	
GG1290E	Pleyt Izgara, Elektrikli, Oluklu Plate Grill, Electrical, Grooved Top	1200 x 900 x 900 mm	400 V / 50 Hz	300 °C	15,3 kW	125 kg	
GS8090E	Pleyt Izgara, Elektrikli, Yarı Oluklu Plate Grill, Electrical, Semi-Grooved Top	800 x 900 x 900 mm	400 V / 50 Hz	300 °C	10,2 kW	85 kg	
GS1290E	Pleyt Izgara, Elektrikli, Yarı Oluklu Plate Grill, Electrical, Semi-Grooved Top	1200 x 900 x 900 mm	400 V / 50 Hz	300 °C	15,3 kW	125 kg	

**PLEYT IZGARA, MONO BLOK, ELEKTRİKLİ
PLATE GRILL, MONO BLOCK, ELECTRICAL**

⚡ GFCS4090E



⚡ GGCS8090E



EN

- Stainless steel body.
- Best cooking performance and homogeneous heat distribution.
- Economic grilling with 12mm plate thickness.
- Various grilling options with flat, grooved or semi grooved models.
- Waste oil easily reach the oil wasteway hole.
- Cooktop temperature is adjustable between 50-300 C with thermostat control.

⚡ GSCS1290E



PRODUCT CODE ÜRÜN KODU	PRODUCT NAME ÜRÜN ADI	Dimension (W x D x H) Ürün Ölçüsü (G x D x Y)	Voltage Gerilim	Temperature Sıcaklık	Power Güç	Net Weight Net Ağırlık	Price Fiyat
GFCS4090E	Pleyt Izgara, Mono Blok, Elektrikli, Düz Plate Grill, Mono Block, Electrical, Flat Top	400 x 900 x 900 mm	400 V / 50 Hz	300 °C	5,1 kW	75 kg	
GFCS8090E	Pleyt Izgara, Mono Blok, Elektrikli, Düz Plate Grill, Mono Block, Electrical, Flat Top	800 x 900 x 900 mm	400 V / 50 Hz	300 °C	10,2 kW	110 kg	
GFCS1290E	Pleyt Izgara, Mono Blok, Elektrikli, Düz Plate Grill, Mono Block, Electrical, Flat Top	1200 x 900 x 900 mm	400 V / 50 Hz	300 °C	15,3 kW	170 kg	
GGCS4090E	Pleyt Izgara, Mono Blok, Elektrikli, Oluklu Plate Grill, Mono Block, Electrical, Grooved Top	400 x 900 x 900 mm	400 V / 50 Hz	300 °C	5,1 kW	75 kg	
GGCS8090E	Pleyt Izgara, Mono Blok, Elektrikli, Oluklu Plate Grill, Mono Block, Electrical, Grooved Top	800 x 900 x 900 mm	400 V / 50 Hz	300 °C	10,2 kW	110 kg	
GGCS1290E	Pleyt Izgara, Mono Blok, Elektrikli, Oluklu Plate Grill, Mono Block, Electrical, Grooved Top	1200 x 900 x 900 mm	400 V / 50 Hz	300 °C	15,3 kW	170 kg	
GSCS8090E	Pleyt Izgara, Mono Blok, Elektrikli, Yarı Oluklu Plate Grill, Mono Block, Electrical, Semi-Grooved Top	800 x 900 x 900 mm	400 V / 50 Hz	300 °C	10,2 kW	110 kg	
GSCS1290E	Pleyt Izgara, Mono Blok, Elektrikli, Yarı Oluklu Plate Grill, Mono Block, Electrical, Semi-Grooved Top	1200 x 900 x 900 mm	400 V / 50 Hz	300 °C	15,3 kW	170 kg	

LAVTAŞ IZGARA, MONO BLOK, GAZLI
LAV STONE GRILL, MONO BLOCK, GAS**LGCS4090G****LGCS8090G****LGCS1290G****TR**

- Paslanmaz çelik gövde
- Pişirme yüzeyi sac ızgara yada döküm ızgara olarak tercih edilebilir.
- 1, 2 ve 3 brülörlü modelleri vardır.
- Gaz muslukları emniyet ventillidir.
- Termokupl ve pilot ateşleme tertibatı vardır.
- Manyetolu çakmağı vardır.
- Yükseklik ayarı yapılabilen ızgaralar sayesinde pişirme hızı ve şiddeti ayarlanabilmektedir.

EN

- Stainless steel body.
- Cooking surface can be preferred as stainless steel grill or cast.
- 1,2,3 burner models are available.
- Equipped with safety valves.
- Equipped piezoelectric ignition system for each burners.
- Distance from burner and back part of cast iron grills are adjustable by front handled lever.

PRODUCT CODE ÜRÜN KODU	PRODUCT NAME ÜRÜN ADI	Dimension (W x D x H) Ürün Ölçüsü (G x D x Y)	Gas Consumption Natural Gas / Propane Gaz Sarfiyatı Doğalgaz / Propan	Power Güç	Net Weight Net Ağırlık	Price Fiyat
LGCS4090G	Lavtaş Izgara, Mono Blok, Gazlı Lav Stone Grill, Mono Block, Gas	400 x 900 x 900 mm	1,292 m ³ /h / 0,386 kg/h	9,5 kW	95 kg	
LGCS8090G	Lavtaş Izgara, Mono Blok, Gazlı Lav Stone Grill, Mono Block, Gas	800 x 900 x 900 mm	2,584 m ³ /h / 0,772 kg/h	19,0 kW	160 kg	
LGCS1290G	Lavtaş Izgara, Mono Blok, Gazlı Lav Stone Grill, Mono Block, Gas	1200 x 900 x 900 mm	3,876 m ³ /h / 1,158 kg/h	28,5 kW	210 kg	

SULU IZGARA, MONO BLOK, GAZLI, T MODEL
VAPOUR GRILL, MONO BLOCK, GAS, T MODEL

VGOS4090GT



VGOS8090GT



TR

- Paslanmaz çelik gövde
- 3, 6 ve 9 brülör modelleri ile çok güçlü bir pişirme sağlar.
- Doğalgaz ya da LPG uyumlu
- Kolayca kaldırılabilen mil ızgaralar
- Geniş su çekmecesi sayesinde nemlendirerek pişirme
- Emniyet ventilli gaz musluğu
- Özel tasarım ızgara sayesinde pişirme esnasında oluşan atık yağ kolayca su dolu hazneye aktarılmaktadır
- Bu şekilde ortaya çıkan duman ve koku minimum seviyede tutulur.

EN

- Stainless steel body
- Makes powerful cooking with 3, 6 and 9 burner models.
- Natural gas or LPG compatible
- Easy to remove spindle grills
- Moist cooking due to water drawer
- Equipped with safety valves
- Special design grills easily transfer the grease to water tank
- Fats easily collected at the water filled tray and minimize odour and smoke



VGOS1290GT



PRODUCT CODE ÜRÜN KODU	PRODUCT NAME ÜRÜN ADI	Dimension (W x D x H) Ürün Ölçüsü (G x D x Y)	Gas Consumption Natural Gas / Propane Gaz Sarfiyatı Doğalgaz / Propan	Power Güç	Net Weight Net Ağırlık	Price Fiyat
VGOS4090GT	Sulu Izgara, Mono Blok, Gazlı, T Model Vapour Grill, Mono Block, Gas, T Model	400 x 900 x 900 mm	1,780 m ³ /h / 1,310 kg/h	15,0 kW	95 kg	
VGOS8090GT	Sulu Izgara, Mono Blok, Gazlı, T Model Vapour Grill, Mono Block, Gas, T Model	800 x 900 x 900 mm	3,640 m ³ /h / 2,690 kg/h	30,5 kW	160 kg	
VGOS1290GT	Sulu Izgara, Mono Blok, Gazlı, T Model Vapour Grill, Mono Block, Gas, T Model	1200 x 900 x 900 mm	4,960 m ³ /h / 3,660 kg/h	45,5 kW	210 kg	

**FRİTÖZ, MONO BLOK ELEKTRİKLİ
FRYER, MONO BLOCK, ELECTRICAL****FCS4090E****TR**

- Paslanmaz çelik gövde
- Fritöz sepeti paslanmaz sac malzemeden yapılmıştır.
- Hazne kapasitesi 26 litredir.
- 230 C resetli güvenlik termostatu kullanılmaktadır.
- 180 C termostat kullanılmaktadır.
- Askı tertibatı güvenlik sviçlidir.
- Rezistanslar yukarı yönlü kaldırılarak kolayca temizlenebilir.
- Yağ haznesinin altında yer alan emniyetli yağ tahliyesi sayesinde yağ boşaltma kolayca yapılmaktadır ve olası kazaların önüne geçilmektedir.

EN

- Stainless steel body
- Fryer basket is made of stainless stell.
- Fat capacity of each bowl is 26 liters.
- Equipped with 230 C reset security thermostat.
- Equipped with 180 C thermostat.
- Equipped with swich at resistance rack.
- Resistance could be swing and hand up to top rack easily for cleaning.
- Equipped with fat remove tap. Easy and safe to remove fat with the adjustable tap handle.

PRODUCT CODE ÜRÜN KODU	PRODUCT NAME ÜRÜN ADI	Dimension (W x D x H) Ürün Ölçüsü(G x D x Y)	Kapasite Capacity	Voltage Gerilim	Temperature Sıcaklık	Power Güç	Net Weight Net Ağırlık	Price Fiyat
FCS4090E	Fritöz, Mono Blok, Elektrikli Fryer, Mono Block, Electrical	400 x 900 x 900 mm	26 lt	400 V	180 °C	19,0 kW	40 kg	

STAND, SNACK SERİ
STAND, SNACK SERIE

CS4090



CS8090



CS1290



OS4090



OS8090



OS1290



PRODUCT CODE ÜRÜN KODU	PRODUCT NAME ÜRÜN ADI	Dimension (W x D x H) Ürün Ölçüsü(G x D x Y)	Net Weight Net Ağırlık	Price Fiyat
CS4090	Stand, Kapaklı / Stand, Cabinet	400 x 750 x 620 mm	20 kg	
CS8090	Stand, Kapaklı / Stand, Cabinet	800 x 750 x 620 mm	25 kg	
CS1290	Stand, Kapaklı / Stand, Cabinet	1200 x 750 x 620 mm	30 kg	
OS4090	Stand, Kapaksız / Stand, Coverless	400 x 750 x 620 mm	15 kg	
OS8090	Stand, Kapaksız / Stand, Coverless	800 x 750 x 620 mm	20 kg	
OS1290	Stand, Kapaksız / Stand, Coverless	1200 x 750 x 620 mm	25 kg	

MANGAL

BARBECUE



Mangal, Kömürlü, Filtreli / Barbecue, Charcoal, With Filter

MANGAL, KÖMÜRLÜ, FİLTRELİ
BARBECUE, CHARCOAL, WITH FILTER

BCF130



BCF150



BCF170



BCF200



TR

- Paslanmaz çelikten imal edilmiştir.
- Pişirme haznesi ateş tuğlası ile döşenmiştir.
- Davlumbaz filtrelidir.
- Hem kömür ateşinde hem de odun ateşinde pişirme imkanı vardır.
- Ayakları ayarlanabilir.

EN

- Stainless steel body
- Cooking chamber is furnished with firebrick.
- Hood with filter.
- It is possible to cook both on coal fire and wood fire.
- Feet are adjustable.

PRODUCT CODE ÜRÜN KODU	PRODUCT NAME ÜRÜN ADI	Dimension (W x D x H) Ürün Ölçüsü (G x D x Y)	Pişirme Alanı Cooking Surface	Net Weight Net Ağırlık	Price Fiyat
BCF130	Mangal, Kömürlü, Filtreli Barbecue, Charcoal with Filter	1300 x 530 x 1200 mm	1170 x 470 mm	110 kg	
BCF150	Mangal, Kömürlü, Filtreli Barbecue, Charcoal with Filter	1500 x 530 x 1200 mm	1370 x 470 mm	135 kg	
BCF170	Mangal, Kömürlü, Filtreli Barbecue, Charcoal with Filter	1700 x 530 x 1200 mm	1570 x 470 mm	160 kg	
BCF200	Mangal, Kömürlü, Filtreli Barbecue, Charcoal with Filter	2000 x 530 x 1200 mm	1870 x 470 mm	195 kg	

DÖNER ROBOTLARI

DONER ROBOTS

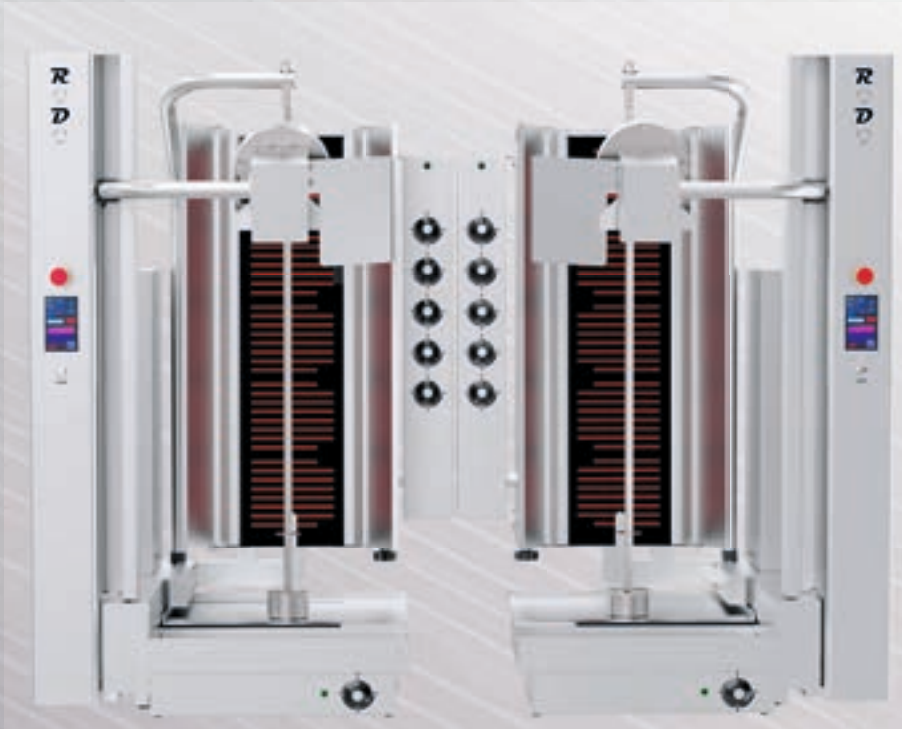

Döner Robotu, Gazlı / Doner Robot, Gas

Döner Robotu, Elektrikli / Doner Robot, Electrical

DÖNER ROBOTU, GAZLI
DONER ROBOT, GAS

TR

- Uzaktan erişim sayesinde uzaktan teknik destek verilebilir.
- Çoklu dil seçenekleri ve kullanıcı dostu kontrol paneli vardır.
- Silindirik, konik veya ters konik kesim özelliği vardır.
- Kesim kalınlığı ayarlanabilir.
- Standart kesim ve geniş kesim seçenekleri sunar.
- Kesim hızı ve et dönüş hızı ayarlanabilir.
- Sol kol ve sağ kol opsiyonları vardır.
- Et tipine göre pişirme seçenekleri sağlar.
- Minimum fire ile verimlilik sağlar.
- Kolay sökülen parçaları ile hijyeniktir.
- Bıçak uzun ömürlüdür.
- Ergonomik bıçak bileme modu vardır.
- Benmari sistemi sayesinde kesilen et sıcak ve nemli olarak bekletilebilir.

VIDEO



RODO5G



EN

- Provides technical supports thanks to Remote Access,
- Multi-Language and User-Friendly interface,
- Can work with conical and cylindrical meat types,
- Adjustable cutting thickness,
- Standart and Wide Size cutting,
- Adjustable cutting and rotation speed,
- The cutting arm can be produced on the right or on the left
- Adjustable cooking programs based on meat type,
- Efficient, works with minimum waste,
- Easily removable components are hygienic
- Long-Lasting Knife,
- Ergonomic Knife Sharpening Mode,
- Cutted meat remains hot and humidified on bain-marie heating system.

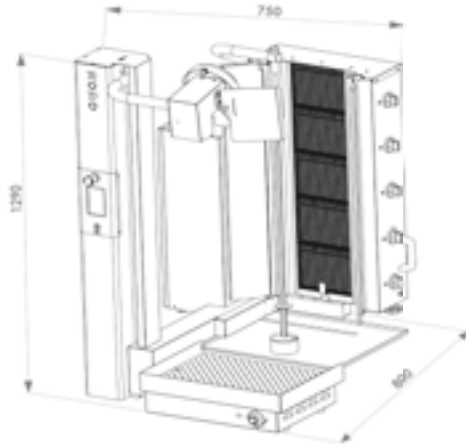
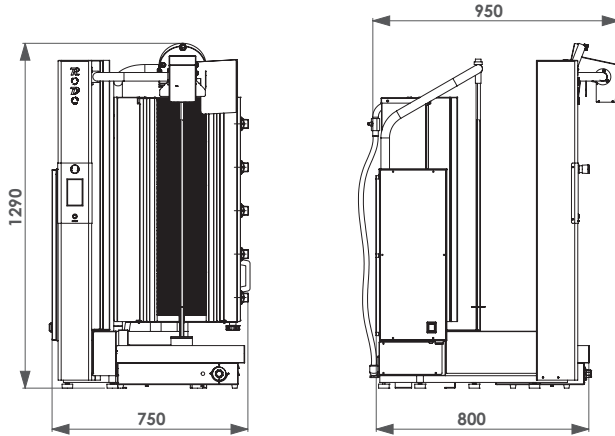

ÜRÜN KODU / PRODUCT CODE	RODO4G	RODO5G
Radyan / Burner	4	5
Genişlik / Width	750 mm	750 mm
Derinlik / Depth	800 mm	800 mm
Yükseklik / Height	1130 mm	1290 mm
Kapasite / Capacity	70 kg	100 kg
Gerilim / Voltage	230 V / 50 Hz	230 V / 50 Hz
Güç / Power	13,00 kW	16,25 kW
Tüketim / Consumption	1,355 m ³ /h	1,694 m ³ /h
Ağırlık / Weight	115 kg	120 kg
Fiyat / Price		

ÜRÜN KODU / PRODUCT CODE	RODO4G	RODO5G
Radyan / Burner	4	5
Genişlik / Width	29,5"	29,5"
Derinlik / Depth	31,5"	31,5"
Yükseklik / Height	44,5"	50,8"
Et Kapasitesi / Capacity	155 lbs	220 lbs
Gerilim / Voltage*	230 V / 50 Hz	230 V / 50 Hz
Güç / Power	44360 BTU	55450 BTU
Tüketim / Consumption	47,85 ft ³ /h	59,82 ft ³ /h
Net Ağırlık / Weight	250 lbs	260 lbs

* Şehir gerilimi 110 V olan ülkelere gönderilen ürünler 110 V ayarlı olarak üretilmektedir.
* Products sent to countries with 110 V city voltage are produced with 110 V adjustment.

DÖNER ROBOTU, ELEKTRİKLİ
DONER ROBOT, ELECTRICAL



RODO5E



VIDEO



TR

- Uzaktan erişim sayesinde uzaktan teknik destek verilebilir.
- Çoklu dil seçenekleri ve kullanıcı dostu kontrol paneli vardır.
- Silindirik, konik veya ters konik kesim özelliği vardır.
- Kesim kalınlığı ayarlanabilir.
- Standart kesim ve geniş kesim seçenekleri sunar.
- Kesim hızı ve et dönüş hızı ayarlanabilir.
- Sol kol ve sağ kol opsiyonları vardır.
- Et tipine göre pişirme seçenekleri sağlar.
- Minimum fire ile verimlilik sağlar.
- Kolay sökülen parçaları ile hijyeniktir.
- Bıçak uzun ömürlüdür.
- Ergonomik bıçak bileme modu vardır.
- Benmari sistemi sayesinde kesilen et sıcak ve nemli olarak bekletilebilir.

EN

- Provides technical supports thanks to Remote Access,
- Multi-Language and User-Friendly interface,
- Can work with conical and cylindrical meat types,
- Adjustable cutting thickness,
- Standart and Wide Size cutting,
- Adjustable cutting and rotation speed,
- The cutting arm can be produced on the right or on the left
- Adjustable cooking programs based on meat type,
- Efficient, works with minimum waste,
- Easily removable components are hygenic
- Long-Lasting Knife,
- Ergonomic Knife Sharpening Mode,
- Cutted meat remains hot and humidified on bain-marie heating system.

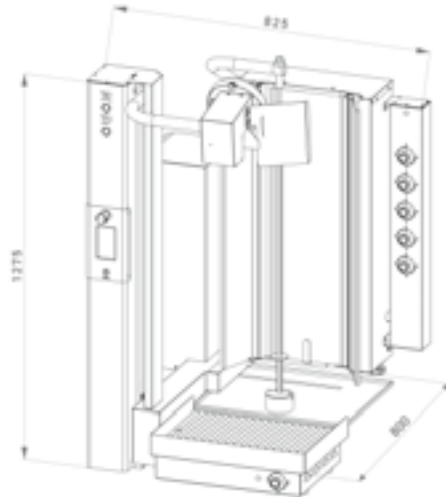
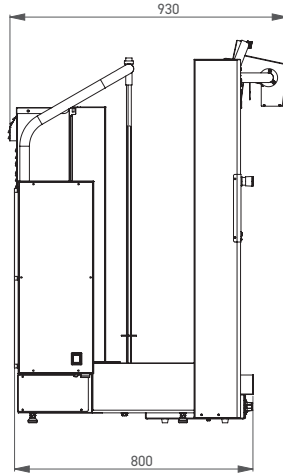
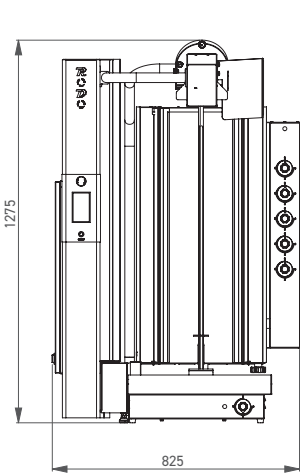

EU ÜRÜN KODU / PRODUCT CODE	RODO4E	RODO5E
Radyan / Burner	4	5
Genişlik / Width	825 mm	825 mm
Derinlik / Depth	800 mm	800 mm
Yükseklik / Height	1120 mm	1275 mm
Kapasite / Capacity	70 kg	100 kg
Gerilim / Voltage	230 V / 50 Hz	230 V / 50 Hz
Güç / Power	7,2 kW	9 kW
Ağırlık / Weight	115 kg	120 kg
Fiyat / Price		

US ÜRÜN KODU / PRODUCT CODE	RODO4E	RODO5E
Radyan / Burner	4	5
Genişlik / Width	32,5"	32,5"
Derinlik / Depth	31,5"	31,5"
Yükseklik / Height	44,5"	50,8"
Kapasite / Capacity	155 lbs	220 lbs
Gerilim / Voltage*	400 V / 50 Hz	400 V / 50 Hz
Güç / Power	24570 BTU	30710 BTU
Ağırlık / Weight	250 lbs	260 lbs

* Bulunduğunuz bölgedeki trifaz gerilimi tablodaki değerden farklıysa bizimle iletişime geçebilirsiniz.
* If the three-phase voltage in your region is different from the value in the table, you can contact us.

DÖNER OCAKLARI

DONER KEBAB GRILLS

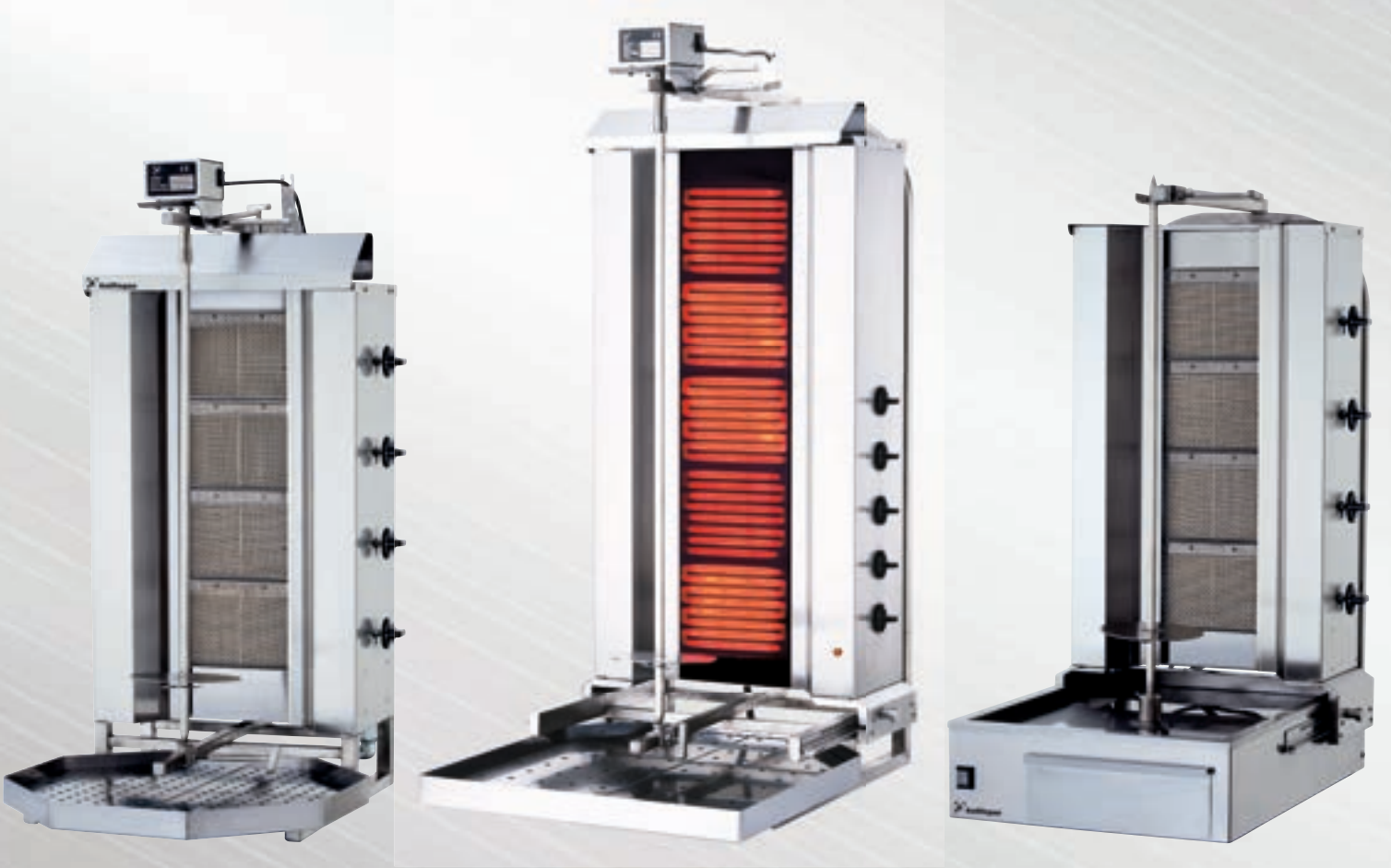

- Gazlı Döner Ocağı, Altan Motorlu / Gas Doner Grill, Bottom Motor
- Elektrikli Döner Ocağı, Altan Motorlu / Electrical Doner Grill, Bottom Motor
- Gazlı Döner Ocağı, Üstten Motorlu / Gas Doner Grill, Top Motor
- Elektrikli Döner Ocağı, Üstten Motorlu / Electrical Doner Grill, Top Motor
- Gazlı Döner Ocağı, Motorsuz / Gas Doner Grill, Without Motor
- Elektrikli Döner Ocağı, Motorsuz / Electrical Doner Grill, Without Motor
- Döner Kesme Bıçağı, Elektrikli / Doner Slicer, Electrical
- Döner Küreği / Doner Shovel
- Döner Ocağı Aksesuarları / Accessories for Doner Kebab Grills
- Döner Taşıma Lifti / Meat Lifting Trolley
- Döner Robot Standı / Doner Robot Stand

GAZLI, ALTAN MOTORLU, HAREKETLİ GÖVDE
GAS, BOTTOM MOTOR, MOVING BODY



KL151



TR

- Doğalgaz veya Propan (LPG)
- 12 mm genişliğinde içi dolu, paslanmaz kılıç ve et sacı
- Talebe göre opsiyonel sağ ve sol rüzgarlık kanat takımı
- Talebe göre opsiyonel tepsi genişletme sacı ve yağ süzgeci
- Emniyet ventilli gaz valfi
- Altan motorlu (Çift yönde dönebilme özelliği)
- Gövde hareketli (Isıtıcılar döner etine yaklaşır)
- Paslanmaz çelik gövdeli
- AISI-310S Cr-Ni radyan koruma teli
- Hijyenik, emniyetli ve uzun ömürlü

EN

- Natural gas or Propan (LPG)
- 12mm solid and stainless skewer and skewer plate
- Optional wind wings set (Left & Right)
- Optional fat tray extension part and strainer
- Equipped with safety gas valve
- Motor at bottom (Reversible motor)
- Moving body (Burners can come close to doner meat)
- Stainless steel body
- AISI-310 S Cr-Ni burner cover
- Hygienic, safe and long lasting

EU ÜRÜN KODU / PRODUCT CODE	KL153	KL150	KL151	KL152	KL156
Radyan / Burner	3 (Dik / Vertical)	3	4	5	6
Genişlik / Width	485 mm	550 mm	550 mm	550 mm	550 mm
Derinlik / Depth	715 mm	715 mm	715 mm	715 mm	715 mm
Yükseklik / Height	1065 mm	900 mm	1065 mm	1230 mm	1395 mm
Ağırlık / Weight	35 kg	35 kg	40 kg	45 kg	50 kg
Gerilim / Voltage	230 V / 50 Hz	230 V / 50 Hz	230 V / 50 Hz	230 V / 50 Hz	230 V / 50 Hz
Kapasite / Capacity	40 kg	40 kg	60 kg	80 kg	100 kg
Tüketim / Consumption	1,016 m ³ /h	1,016 m ³ /h	1,355 m ³ /h	1,694 m ³ /h	2,053 m ³ /h
Güç / Power	9,75 kW	9,75 kW	13,00 kW	16,25 kW	19,50 kW
Fiyat / Price					

US ÜRÜN KODU / PRODUCT CODE	KL153	KL150	KL151	KL152	KL156
Radyan / Burner	3 (Dik / Vertical)	3	4	5	6
Genişlik / Width	19,1"	21,7"	21,7"	21,7"	21,7"
Derinlik / Depth	28,1"	28,1"	28,1"	28,1"	28,1"
Yükseklik / Height	41,9"	35,4"	41,9"	48,4"	54,9"
Ağırlık / Weight	77 lbs	77 lbs	88 lbs	99 lbs	110 lbs
Gerilim / Voltage*	230 V / 50 Hz	230 V / 50 Hz	230 V / 50 Hz	230 V / 50 Hz	230 V / 50 Hz
Kapasite / Capacity	90 lbs	90 lbs	130 lbs	175 lbs	220 lbs
Tüketim / Consumption	35,88 ft ³ /h	35,88 ft ³ /h	47,85 ft ³ /h	59,82 ft ³ /h	72,5 ft ³ /h
Güç / Power	33270 BTU	33270 BTU	44360 BTU	55450 BTU	66530 BTU

* Şehir gerilimi 110 V olan ülkelere gönderilen ürünler 110 V ayarlı olarak üretilmektedir.

* Products sent to countries with 110 V city voltage are produced with 110 V adjustment.

GAZLI, ALTAN MOTORLU, HAREKETLİ GÖVDE, İKİZ MODEL
GAS, BOTTOM MOTOR, MOVING BODY, TWIN MODEL

TR

- Doğalgaz veya Propan (LPG)
- 12 mm genişliğinde içi dolu, paslanmaz kılıç ve et sacı
- Talebe göre opsiyonel sağ ve sol rüzgarlık kanat takımı
- Talebe göre opsiyonel tepsi genişletme sacı ve yağ süzgeci
- Emniyet ventilli gaz valfi
- Altan motorlu (Çift yönde dönebilme özelliği)
- Gövde hareketli (Isıtıcılar döner etine yaklaşır)
- Ayarlanabilir döner şişi
- Paslanmaz çelik gövdeli
- AISI-310S Cr-Ni radyan koruma teli
- 3+3 dik radyan seçeneği

EN

- Natural gas or Propan (LPG)
- 12 mm solid and stainless skewer and skewer plate
- Optional wind wings set (Left & Right)
- Optional fat tray extension part and strainer
- Equipped with safety gas valve
- Motor at bottom (Reversible motor)
- Moving body (Burners can come close to doner meat)
- Adjustable skewer
- Stainless steel body
- AISI-310 S Cr-Ni burner cover
- Optional 3+3 vertical burner



KL224T



EU ÜRÜN KODU / PRODUCT CODE	KL2 153-T	KL2 224-T	KL2 225-T
Radyan / Burner	3+3 (Dik / Vertical)	4+4	5+5
Genişlik / Width	890 mm	1000 mm	1000 mm
Derinlik / Depth	715 mm	715 mm	715 mm
Yükseklik / Height	1065 mm	1065 mm	1230 mm
Ağırlık / Weight	75 kg	80 kg	85 kg
Gerilim / Voltage	230 V / 50 Hz	230 V / 50 Hz	230 V / 50 Hz
Kapasite / Capacity	80 kg	120 kg	160 kg
Tüketim / Consumption	2,033 m ³ /h	2,710 m ³ /h	3,388 m ³ /h
Güç / Power	19,50 kW	26,00 kW	32,50 kW
Fiyat / Price			

US ÜRÜN KODU / PRODUCT CODE	KL2 153-T	KL2 224-T	KL2 225-T
Radyan / Burner	3+3 (Dik / Vertical)	4+4	5+5
Genişlik / Width	35"	39,4"	39,4"
Derinlik / Depth	28,1"	28,1"	28,1"
Yükseklik / Height	41,9"	41,9"	48,4"
Ağırlık / Weight	165 lbs	176 lbs	187 lbs
Gerilim / Voltage*	230 V / 50 Hz	230 V / 50 Hz	230 V / 50 Hz
Kapasite / Capacity	175 lbs	265 lbs	350 lbs
Tüketim / Consumption	71,79 ft ³ /h	95,7 ft ³ /h	119,65 ft ³ /h
Güç / Power	66530 BTU	88710 BTU	110890 BTU

* Şehir gerilimi 110 V olan ülkelere gönderilen ürünler 110 V ayarlı olarak üretilmektedir.

* Products sent to countries with 110 V city voltage are produced with 110 V adjustment.

GAZLI, ALTAN MOTORLU, HAREKETLİ GÖVDE, V MODEL
GAS, BOTTOM MOTOR, MOVING BODY, V MODEL



KLG225V



TR

- Doğalgaz veya Propan (LPG)
- Emniyet ventilli gaz valfi
- 12 mm genişliğinde içi dolu, paslanmaz kılıç ve et sacı
- Talebe göre opsiyonel sağ ve sol rüzgarlık kanat takımı
- Alttan motorlu (Çift yönde dönebilme özelliği)
- Gövde hareketli (Isıtıcılar döner etine yaklaşır)
- Ayarlanabilir döner şişi
- Paslanmaz çelik gövdeli
- AISI-310S Cr-Ni radyan koruma teli

EN

- Natural gas or Propan (LPG)
- Equipped with safety gas valve
- 12 mm solid and stainless skewer and skewer plate
- Optional wind wings set (Left & Right)
- Motor at bottom (Reversible motor)
- Moving body (Burners can come close to doner meat)
- Adjustable skewer
- Stainless steel body
- AISI-310 S Cr-Ni burner cover

ÜRÜN KODU / PRODUCT CODE	KLG 223-V	KLG 224-V	KLG 225-V	KLG 226-V
Radyan / Burner	3+3 (Dik / Vertical)	4+4	5+5	6+6
Genişlik / Width	550 mm	750 mm	750 mm	750 mm
Derinlik / Depth	715 mm	800 mm	800 mm	800 mm
Yükseklik / Height	1065 mm	1065 mm	1230 mm	1390 mm
Ağırlık / Weight	50 kg	64 kg	71 kg	78 kg
Gerilim / Voltage	230 V / 50 Hz	230 V / 50 Hz	230 V / 50 Hz	230 V / 50 Hz
Kapasite / Capacity	70 kg	90 kg	120 kg	150 kg
Tüketim / Consumption	2,033 m ³ /h	2,710 m ³ /h	3,388 m ³ /h	4,066 m ³ /h
Güç / Power	19,50 kW	26,00 kW	32,50 kW	39,00 kW
Fiyat / Price				

ÜRÜN KODU / PRODUCT CODE	KLG 223-V	KLG 224-V	KLG 225-V	KLG 226-V
Radyan / Burner	3+3 (Dik / Vertical)	4+4	5+5	6+6
Genişlik / Width	21,7 "	29,5 "	29,5 "	29,5 "
Derinlik / Depth	28,2 "	31,5 "	31,5 "	31,5 "
Yükseklik / Height	41,9 "	41,9 "	48,4 "	54,7 "
Ağırlık / Weight	110 lbs	141 lbs	156 lbs	172 lbs
Gerilim / Voltage	230 V / 50 Hz	230 V / 50 Hz	230 V / 50 Hz	230 V / 50 Hz
Kapasite / Capacity	155 lbs	200 lbs	265 lbs	330 lbs
Tüketim / Consumption	71,79 ft ³ /h	95,7 ft ³ /h	119,65 ft ³ /h	143,59 ft ³ /h
Güç / Power	66530 BTU	88710 BTU	110890 BTU	133070 BTU

* Şehir gerilimi 110 V olan ülkelere gönderilen ürünler 110 V ayarlı olarak üretilmektedir.

* Products sent to countries with 110 V city voltage are produced with 110 V adjustment.

GAZLI, ALTAN MOTORLU, HAREKETLİ GÖVDE, V MODEL, ARABALI GAS, BOTTOM MOTOR, MOVING BODY, V MODEL, WITH TROLLEY



KL225 VA



KL225 VAD



TR

- Doğalgaz veya Propan (LPG)
- Emniyet ventilli gaz valfi
- Altan motorlu (Çift yönde dönebilme özelliği)
- Gövde hareketli (Isıtıcılar Döner etine yaklaşır)
- Tekerlekli arabası mutfağa veya başka yere rahatça götürülebilir ve döner eti üzerinde takılır
- AISI-310S Cr-Ni radyan koruma teli
- Gövde alt kasasında ısıtıcı bulunur

EN

- Natural gas or Propan (LPG)
- Equipped with safety gas valve
- Motor at bottom (Reversible motor)
- Moving body (Burners can come close to doner meat)
- Doner grill can be taken to kitchen or another place with trolley easily and doner meat can be put on skewer
- AISI-310 S Cr-Ni burner cover
- It has a heater under the body



EU	ÜRÜN KODU / PRODUCT CODE	KL225-VA Dolapsız With Trolley	KL226-VA Dolapsız With Trolley	KL225-VAD Dolaplı With Trolley & Cabinet	KL226-VAD Dolaplı With Trolley & Cabinet
	Radyan / Burner	5+5	6+6	5+5	6+6
Üst Bölüm Upper Part	Ölçü (G x D x Y) / Dimension (W x D x H)	750 x 850 x 1840 mm	750 x 850 x 2000 mm	750 x 850 x 1840 mm	750 x 850 x 2000 mm
	Ağırlık / Weight	80 kg	90 kg	80 kg	90 kg
Alt Bölüm Lower Part	Ölçü (G x D x Y) / Dimension (W x D x H)	850 x 920 x 780 mm	850 x 920 x 780 mm	850 x 920 x 780 mm	850 x 920 x 780 mm
	Ağırlık / Weight	80 kg	80 kg	100 kg	100 kg
	Gerilim / Voltage	230 V / 50 Hz	230 V / 50 Hz	230 V / 50 Hz	230 V / 50 Hz
	Kapasite / Capacity	300 kg	400 kg	300 kg	400 kg
	Tüketim / Consumption	3,388 m ³ /h	4,066 m ³ /h	3,388 m ³ /h	4,066 m ³ /h
	Güç / Power	32,50 kW	39,00 kW	32,50 kW	39,00 kW
	Fiyat / Price				

US	ÜRÜN KODU / PRODUCT CODE	KL225-VA Dolapsız With Trolley	KL226-VA Dolapsız With Trolley	KL225-VAD Dolaplı With Trolley & Cabinet	KL226-VAD Dolaplı With Trolley & Cabinet
	Radyan / Burner	5+5	6+6	5+5	6+6
Üst Bölüm Upper Part	Ölçü (G x D x Y) / Dimension (W x D x H)	29,5 x 33,5 x 72,5"	29,5 x 33,5 x 78,8"	29,5 x 33,5 x 72,5"	29,5 x 33,5 x 78,8"
	Ağırlık / Weight	176 lbs	198 lbs	176 lbs	198 lbs
Alt Bölüm Lower Part	Ölçü (G x D x Y) / Dimension (W x D x H)	33,5 x 36,2 x 30,7"	33,5 x 36,2 x 30,7"	33,5 x 36,2 x 30,7"	33,5 x 36,2 x 30,7"
	Ağırlık / Weight	176 lbs	176 lbs	220 lbs	220 lbs
	Gerilim / Voltage*	230 V / 50 Hz	230 V / 50 Hz	230 V / 50 Hz	230 V / 50 Hz
	Kapasite / Capacity	660 lbs	880 lbs	660 lbs	880 lbs
	Tüketim / Consumption	119,65 ft ³ /h	143,59 ft ³ /h	119,65 ft ³ /h	143,59 ft ³ /h
	Güç / Power	110890 BTU	133070 BTU	110890 BTU	133070 BTU

* Şehir gerilimi 110 V olan ülkelere gönderilen ürünler 110 V ayarlı olarak üretilmektedir.

* Products sent to countries with 110 V city voltage are produced with 110 V adjustment.

**GAZLI, MOTORSUZ, HAREKETLİ GÖVDE, V MODEL, ISITICILI
GAS, WITHOUT MOTOR, MOVING BODY, V MODEL, WITH HEATER****KLG142VH****TR**

- Doğalgaz veya Propan (LPG)
- Emniyet ventilli gaz valfi
- Gövde hareketli (Isıtıcılar döner etine yaklaşır)
- Döner eti üzerinde takılır
- Paslanmaz çelik gövdeli
- AISI-310S Cr-Ni radyan koruma teli
- Hijyenik, emniyetli ve uzun ömürlü

EN

- Natural gas or Propan (LPG)
- Equipped with safety gas valve
- Moving body (Burners can come close to doner meat)
- Doner meat can be put on skewer
- Stainless steel body
- AISI-310 S Cr-Ni burner cover
- Hygienic, safe and long lasting

EU ÜRÜN KODU / PRODUCT CODE	KLG142VH	KLG146VH
Radyan / Burner	5+5	6+6
Genişlik / Width	750 mm	750 mm
Derinlik / Depth	1100 mm	1100 mm
Yükseklik / Height	1210 mm	1375 mm
Ağırlık / Weight	95 kg	103 kg
Gerilim / Voltage	230 V / 50 Hz	230 V / 50 Hz
Kapasite / Capacity	150 kg	200 kg
Tüketim / Consumption	3,388 m ³ /h	4,066 m ³ /h
Güç / Power	32,50 kW	39,00 kW
Fiyat / Price		

US ÜRÜN KODU / PRODUCT CODE	KLG142VH	KLG146VH
Radyan / Burner	5+5	6+6
Genişlik / Width	29,5"	29,5"
Derinlik / Depth	43,3"	43,3"
Yükseklik / Height	47,6"	54,1"
Ağırlık / Weight	209 lbs	227 lbs
Gerilim / Voltage*	230 V / 50 Hz	230 V / 50 Hz
Kapasite / Capacity	330 lbs	440 lbs
Tüketim / Consumption	119,65 ft ³ /h	143,59 ft ³ /h
Güç / Power	110890 BTU	133070 BTU

* Şehir gerilimi 110 V olan ülkelere gönderilen ürünler 110 V ayarlı olarak üretilmektedir.

* Products sent to countries with 110 V city voltage are produced with 110 V adjustment.

GAZLI, ALTAN MOTORLU, HAREKETLİ GÖVDE, ÖZEL MODEL
GAS, BOTTOM MOTOR, MOVING BODY, SPECIAL MODEL

TR

- Doğalgaz veya Propan (LPG)
- Talebe göre opsiyonel 12 mm veya 16 mm içi dolu paslanmaz kılıç
- Daha etkili pişirme için eğimli üst gövde sacı
- Talebe göre opsiyonel sağ ve sol rüzgarlık kanat takımı
- Talebe göre opsiyonel tepsi genişletme sacı ve yağ süzgeci
- Emniyet ventilli gaz valfi
- Gövde hareketli (Isıtıcılar döner etine yaklaşır)
- Paslanmaz çelik gövdeli
- AISI-310S Cr-Ni radyan koruma teli
- Hijyenik, emniyetli ve uzun ömürlü

EN

- Natural gas or Propan (LPG)
- Optional 12 mm or 16 mm inner stainless steel sword
- Curved top body providing better cooking performance
- Optional wind wings set (Left & Right)
- Optional fat tray extension part and strainer
- Equipped with safety gas valve
- Moving body (Burners can come close to doner meat)
- Stainless steel body
- AISI-310 S Cr-Ni burner cover
- Hygienic, safe and long lasting



KLG151S



EU ÜRÜN KODU / PRODUCT CODE	KLG 150-S	KLG 151-S	KLG 152-S
Radyan / Burner	3	4	5
Genişlik / Width	550 mm	550 mm	550 mm
Derinlik / Depth	715 mm	715 mm	715 mm
Yükseklik / Height	900 mm	1065 mm	1230 mm
Ağırlık / Weight	35 kg	40 kg	45 kg
Gerilim / Voltage	230 V / 50 Hz	230 V / 50 Hz	230 V / 50 Hz
Kapasite / Capacity	40 kg	60 kg	80 kg
Tüketim / Consumption	1,016 m ³ /h	1,355 m ³ /h	1,694 m ³ /h
Güç / Power	9,75 kW	13,00 kW	16,25 kW
Fiyat / Price			

US ÜRÜN KODU / PRODUCT CODE	KLG 150-S	KLG 151-S	KLG 152-S
Radyan / Burner	3	4	5
Genişlik / Width	21,7"	21,7"	21,7"
Derinlik / Depth	28,1"	28,1"	28,1"
Yükseklik / Height	35,4"	41,9"	48,4"
Ağırlık / Weight	77 lbs	88 lbs	99 lbs
Gerilim / Voltage*	230 V / 50 Hz	230 V / 50 Hz	230 V / 50 Hz
Kapasite / Capacity	90 lbs	130 lbs	175 lbs
Tüketim / Consumption	35,88 ft ³ /h	47,85 ft ³ /h	59,82 ft ³ /h
Güç / Power	33270 BTU	44360 BTU	55450 BTU

* Şehir gerilimi 110 V olan ülkelere gönderilen ürünler 110 V ayarlı olarak üretilmektedir.

* Products sent to countries with 110 V city voltage are produced with 110 V adjustment.

**CHEF DÖNER
CHEF DONER**



KL252

TR

- Eti geniş kesmek isteyen kullanıcılar için özel olarak tasarlanmıştır.
- Radyanların geniş olması sebebiyle daha fazla alanı pişirebilme özelliğine sahiptir.
- Kare şeklindeki eti homojen bir şekilde pişirebilme özelliğine sahiptir.
- Güçlü motoru sayesinde 120 kilograma kadar et pişirebilme özelliğine sahiptir.
- Doğalgaz veya Propan (LPG) ile çalışır.
- 12 mm genişliğinde içi dolu, paslanmaz kılıç ve et sacına sahiptir.
- Talebe göre opsiyonel sağ ve sol rüzgarlık kanat takımı mevcuttur.
- Talebe göre opsiyonel tepsi genişletme sacı ve yağ süzgeci mevcuttur.
- Emniyet ventilli gaz valfi ile donatılmıştır.
- Alttan motorlu (Çift yönde dönebilme özelliği).
- Gövde hareketli (Isıtıcılar döner etine yaklaşır).
- Paslanmaz çelik gövdeli yapısıyla hijyenik kullanım sunar.
- AISI-310S Cr-Ni radyan koruma teli ile uzun ömürlü kullanım sunar.

EN

- This grill is specially designed for users who want to cut wide meat.
- Due to large burners, it has the ability to cook more space.
- This grill has the ability to cook square-shaped meat homogeneously.
- Due to its powerful motor, it has the ability to cook up to 120 kilograms of meat.
- Natural gas or Propan (LPG).
- 12mm solid and stainless skewer and skewer plate.
- Optional wind wings set (Left & Right).
- Optional fat tray extension part and strainer.
- Equipped with safety gas valve.
- Motor at bottom (Reversible motor).
- Moving body (Burners can come close to doner meat).
- Stainless steel body.
- AISI-310 S Cr-Ni burner cover.

EU ÜRÜN KODU / PRODUCT CODE	KL251	KL252	KL253
Radyan / Burner	4	5	6
Genişlik / Width	835 mm	835 mm	835 mm
Derinlik / Depth	930 mm	930 mm	930 mm
Yükseklik / Height	1055 mm	1220 mm	1385 mm
Ağırlık / Weight	58 kg	65 kg	74 kg
Gerilim / Voltage	230 V / 50 Hz	230 V / 50 Hz	230 V / 50 Hz
Kapasite / Capacity	90 kg	120 kg	150 kg
Tüketim / Consumption	1,612 m ³ /h	2,015 m ³ /h	2,418 m ³ /h
Güç / Power	17,2 kW	21,5 kW	25,8 kW
Fiyat / Price			

US ÜRÜN KODU / PRODUCT CODE	KL251	KL252	KL253
Radyan / Burner	4	5	6
Genişlik / Width	32,9"	36,6"	41,5"
Derinlik / Depth	32,9"	36,6"	41,5"
Yükseklik / Height	41,5"	48"	54,5"
Ağırlık / Weight	128 lbs	143 lbs	163 lbs
Gerilim / Voltage*	230 V / 50 Hz	230 V / 50 Hz	230 V / 50 Hz
Kapasite / Capacity	200 lbs	265 lbs	330 lbs
Tüketim / Consumption	56,93 ft ³ /h	71,16 ft ³ /h	85,39 ft ³ /h
Güç / Power	58690 BTU	73360 BTU	88030 BTU

* Şehir gerilimi 110 V olan ülkelere gönderilen ürünler 110 V ayarlı olarak üretilmektedir.

* Products sent to countries with 110 V city voltage are produced with 110 V adjustment.

ELEKTRİKLİ, ALTAN MOTORLU, HAREKETLİ GÖVDE, CAMLI
ELECTRICAL, BOTTOM MOTOR, MOVING BODY, WITH GLASS

TR

- ROBAX Color S termal camlı
- 12 mm genişliğinde içi dolu, paslanmaz kılıç ve et sacı
- Talebe göre opsiyonel sağ ve sol rüzgarlık kanat takımı
- Talebe göre opsiyonel tepsi genişletme sacı ve yağ süzgeci
- İki kademeli pişirme sıcaklığı (Düşük & Yüksek)
- Altan motorlu (Çift yönde dönebilme özelliği)
- Gövde hareketli (Isıtıcılar döner etine yaklaşır)
- Ayarlanabilir döner şişi
- Paslanmaz çelik gövdeli

EN

- ROBAX Color S thermal glass
- 12 mm solid and stainless skewer and skewer plate
- Optional wind wings set (Left & Right)
- Optional fat tray extension part and strainer
- Two different level cooking temperature (Low & High)
- Motor at bottom (Reversible motor)
- Moving body (Burners can come close to doner meat)
- Adjustable skewer
- Stainless steel body



KLG171



EU ÜRÜN KODU / PRODUCT CODE	KLG170	KLG171	KLG172
Radyan / Burner	3	4	5
Genişlik / Width	550 mm	550 mm	550 mm
Derinlik / Depth	715 mm	715 mm	715 mm
Yükseklik / Height	900 mm	1065 mm	1230 mm
Ağırlık / Weight	35 kg	40 kg	45 kg
Gerilim / Voltage	400 V / 50Hz	400 V / 50Hz	400 V / 50Hz
Kapasite / Capacity	40 kg	60 kg	80 kg
Güç / Power	5,40 kW	7,20 kW	9,00 kW
Fiyat / Price			

US ÜRÜN KODU / PRODUCT CODE	KLG170	KLG171	KLG172
Radyan / Burner	3	4	5
Genişlik / Width	21,7"	21,7"	21,7"
Derinlik / Depth	28,2"	28,2"	28,2"
Yükseklik / Height	35,4"	41,9"	48,4"
Ağırlık / Weight	77 lbs	88 lbs	99 lbs
Gerilim / Voltage*	400 V / 50 Hz	400 V / 50 Hz	400 V / 50 Hz
Kapasite / Capacity	90 lbs	130 lbs	175 lbs
Güç / Power	18420 BTU	24570 BTU	30710 BTU

*Bulduğunuz bölgedeki trifaz gerilimi tablodaki değerden farklıysa bizimle iletişime geçebilirsiniz.
*If the three-phase voltage in your region is different from the value in the table, you can contact us.

ELEKTRİKLİ, ALTAN MOTORLU, HAREKETLİ GÖVDE, CAMLI, İKİZ MODEL
ELECTRICAL, BOTTOM MOTOR, MOVING BODY, WITH GLASS, TWIN MODEL



KLG172T



TR

- ROBAX Color S termal camlı
- 12 mm genişliğinde içi dolu, paslanmaz kılıç ve et sacı
- Talebe göre opsiyonel sağ ve sol rüzgarlık kanat takımı
- Talebe göre opsiyonel tepsi genişletme sacı ve yağ süzgeci
- İki kademeli pişirme sıcaklığı (Düşük & Yüksek)
- Altan motorlu (Çift yönde dönebilme özelliği)
- Gövde hareketli (Isıtıcılar döner etine yaklaşır)
- Ayarlanabilir döner şişi
- Paslanmaz çelik gövdeli
- Hijyenik, emniyetli ve uzun ömürlü

EN

- ROBAX Color S thermal glass
- 12 mm solid and stainless skewer and skewer plate
- Optional wind wings set (Left & Right)
- Optional fat tray extension part and strainer
- Two different level cooking temperature (Low & High)
- Motor at bottom (Reversible motor)
- Moving body (Burners can come close to doner meat)
- Adjustable skewer
- Stainless steel body
- Hygienic, safe and long lasting

EU ÜRÜN KODU / PRODUCT CODE	KLG171T	KLG172T
Radyan / Burner	4+4	5+5
Genişlik / Width	1000 mm	1000 mm
Derinlik / Depth	715 mm	715 mm
Yükseklik / Height	1065 mm	1230 mm
Ağırlık / Weight	80 kg	85 kg
Gerilim / Voltage	400 V / 50 Hz	400 V / 50 Hz
Kapasite / Capacity	60 + 60 kg	80 + 80 kg
Güç / Power	14,40 kW	18,00 kW
Fiyat / Price		

US ÜRÜN KODU / PRODUCT CODE	KLG171T	KLG172T
Radyan / Burner	4+4	5+5
Genişlik / Width	39,4"	39,4"
Derinlik / Depth	28,2"	28,2"
Yükseklik / Height	41,9"	48,4"
Ağırlık / Weight	176 lbs	187 lbs
Gerilim / Voltage*	400 V / 50 Hz	400 V / 50 Hz
Kapasite / Capacity	130+130 lbs	175+175 lbs
Güç / Power	49130 BTU	61420 BTU

*Bulduğunuz bölgedeki trifaz gerilimi tablodaki değerden farklıysa bizimle iletişime geçebilirsiniz.
*If the three-phase voltage in your region is different from the value in the table, you can contact us.

ELEKTRİKLİ, ALTAN MOTORLU, HAREKETLİ GÖVDE, CAMLI, V MODEL
ELECTRICAL, BOTTOM MOTOR, MOVING BODY, WITH GLASS, V MODEL

KLG172V

TR

- ROBAX Color S termal camlı
- 12 mm genişliğinde içi dolu, paslanmaz kılıç ve et sacı
- İki kademeli pişirme sıcaklığı (Düşük & Yüksek)
- Alttan motorlu (Çift yönde dönebilme özelliği)
- Gövde hareketli (Isıtıcılar döner etine yaklaşır)
- Ayarlanabilir döner şişi
- Paslanmaz çelik gövdeli

EN

- ROBAX Color S thermal glass
- 12 mm solid and stainless skewer and skewer plate
- Two different level cooking temperature (Low & High)
- Motor at bottom (Reversible motor)
- Moving body (Burners can come close to doner meat)
- Adjustable skewer
- Stainless steel body

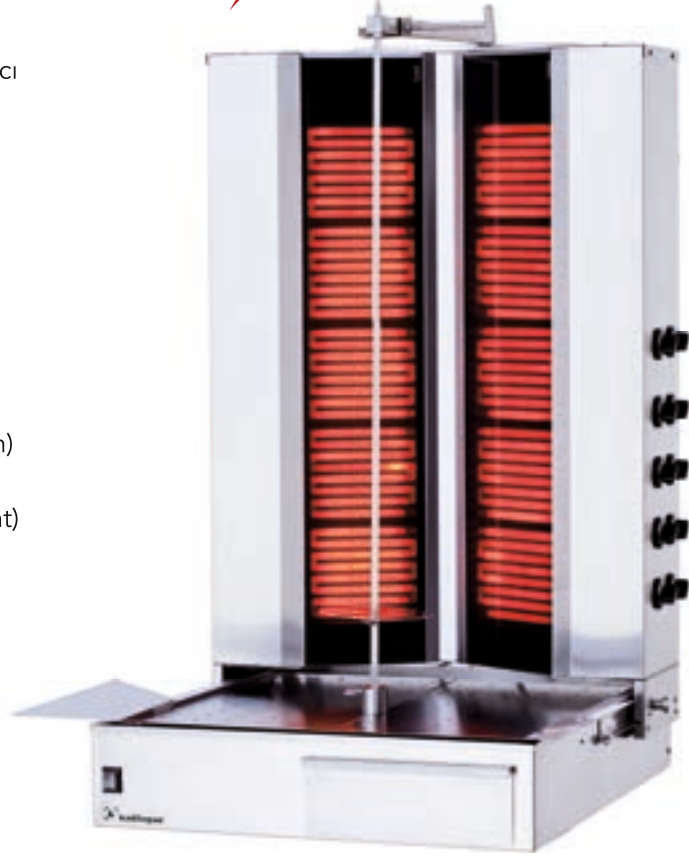

EU ÜRÜN KODU / PRODUCT CODE	KLG171V	KLG172V
Radyan / Burner	4+4	5+5
Genişlik / Width	750 mm	750 mm
Derinlik / Depth	800 mm	800 mm
Yükseklik / Height	1065 mm	1230 mm
Ağırlık / Weight	70 kg	80 kg
Gerilim / Voltage	400 V / 50 Hz	400 V / 50 Hz
Kapasite / Capacity	90 kg	120 kg
Güç / Power	14,40 kW	18,00 kW
Fiyat / Price		

US ÜRÜN KODU / PRODUCT CODE	KLG 171V	KLG 172V
Radyan / Burner	4+4	5+5
Genişlik / Width	29,5"	29,5"
Derinlik / Depth	31,5"	31,5"
Yükseklik / Height	41,9"	48,4"
Ağırlık / Weight	154 lbs	176 lbs
Gerilim / Voltage*	400 V / 50 Hz	400 V / 50 Hz
Kapasite / Capacity	200 lbs	265 lbs
Güç / Power	49130 BTU	61420 BTU

*Bulduğunuz bölgedeki trifaz gerilimi tablodaki değerden farklıysa bizimle iletişime geçebilirsiniz.
*If the three-phase voltage in your region is different from the value in the table, you can contact us.

GAZLI, ÜSTTEN MOTORLU
GAS, TOP MOTOR

KL221

TR

- Doğalgaz veya Propan (LPG)
- 12 mm genişliğinde içi dolu, paslanmaz kılıç ve et sacı
- Talebe göre opsiyonel sağ ve sol rüzgarlık kanat takımı
- Emniyet ventilli gaz valfi
- Üstten motorlu (Çift yönde dönebilme özelliği)
- Ayarlanabilir döner şişi
- Paslanmaz çelik gövdeli
- AISI-310S Cr-Ni radyan koruma teli

EN

- Natural gas or Propan (LPG)
- 12 mm solid and stainless skewer and skewer plate
- Optional wind wings set (Left & Right)
- Equipped with safety gas valve
- Motor at top (Reversible motor)
- Adjustable skewer
- Stainless steel body
- AISI-310 S Cr-Ni burner cover

EU ÜRÜN KODU / PRODUCT CODE	KL225	KL223	KL220	KL221	KL222
Radyan / Burner	1	3 (Dik / Vertical)	3	4	5
Genişlik / Width	330 mm	550 mm	550 mm	550 mm	550 mm
Derinlik / Depth	295 mm	730 mm	700 mm	700 mm	700 mm
Yükseklik / Height	630 mm	1120 mm	960 mm	1120 mm	1285 mm
Ağırlık / Weight	15 kg	30 kg	25 kg	30 kg	35 kg
Gerilim / Voltage	230 V / 50 Hz	230 V / 50 Hz	230 V / 50 Hz	230 V / 50 Hz	230 V / 50 Hz
Kapasite / Capacity	5 kg	40 kg	40 kg	60 kg	80 kg
Tüketim / Consumption	0,339 m ³ /h	1,016 m ³ /h	1,016 m ³ /h	1,355 m ³ /h	1,694 m ³ /h
Güç / Power	3,25 kW	9,75 kW	9,75 kW	13,00 kW	16,25 kW
Fiyat / Price					

US ÜRÜN KODU / PRODUCT CODE	KL225	KL223	KL220	KL221	KL222
Radyan / Burner	1	3 (Dik / Vertical)	3	4	5
Genişlik / Width	13"	21,7"	21,7"	21,7"	21,7"
Derinlik / Depth	11,6"	28,7"	27,6"	27,6"	27,6"
Yükseklik / Height	24,8"	44,1"	37,8"	37,8"	50,6"
Ağırlık / Weight	33 lbs	66 lbs	55 lbs	66 lbs	77 lbs
Gerilim / Voltage*	230 V / 50 Hz	230 V / 50 Hz	230 V / 50 Hz	230 V / 50 Hz	230 V / 50 Hz
Kapasite / Capacity	11 lbs	90 lbs	90 lbs	130 lbs	175 lbs
Tüketim / Consumption	11,97 ft ³ /h	35,88 ft ³ /h	35,88 ft ³ /h	47,85 ft ³ /h	59,82 ft ³ /h
Güç / Power	11090 BTU	33270 BTU	33270 BTU	44360 BTU	55450 BTU

* Şehir gerilimi 110 V olan ülkelere gönderilen ürünler 110 V ayarlı olarak üretilmektedir.

* Products sent to countries with 110 V city voltage are produced with 110 V adjustment.

GAZLI, ÜSTTEN MOTORLU, HAREKETLİ GÖVDE
GAS, TOP MOTOR, MOVING BODY

KLG 221 HG



TR

- Doğalgaz veya Propan (LPG)
- 12 mm genişliğinde içi dolu, paslanmaz kılıç ve et sacı
- Talebe göre opsiyonel sağ ve sol rüzgarlık kanat takımı
- Emniyet ventilli gaz valfi
- Üstten motorlu (Çift yönde dönebilme özelliği)
- Gövde hareketli (Isıtıcılar döner etine yaklaşır)
- Paslanmaz çelik gövdeli
- AISI-310S Cr-Ni radyan koruma teli
- Hijyenik, emniyetli ve uzun ömürlü

EN

- Natural gas or Propan (LPG)
- 12 mm solid and stainless skewer and skewer plate
- Optional wind wings set (Left & Right)
- Equipped with safety gas valve
- Motor at top (Reversible motor)
- Moving body (Burners can come close to doner meat)
- Stainless steel body
- AISI-310 S Cr-Ni burner cover
- Hygienic, safe and long lasting

EU ÜRÜN KODU / PRODUCT CODE	KLG220HG	KLG221HG	KLG222HG
Radyan / Burner	3	4	5
Genişlik / Width	550 mm	550 mm	550 mm
Derinlik / Depth	700 mm	700 mm	700 mm
Yükseklik / Height	960 mm	1120 mm	1285 mm
Ağırlık / Weight	30 kg	35 kg	40 kg
Gerilim / Voltage	230 V / 50 Hz	230 V / 50 Hz	230 V / 50 Hz
Kapasite / Capacity	40 kg	60 kg	80 kg
Tüketim / Consumption	1,016 m ³ /h	1,355 m ³ /h	1,694 m ³ /h
Güç / Power	9,75 kW	13,00 kW	16,25 kW
Fiyat / Price			

US ÜRÜN KODU / PRODUCT CODE	KLG220HG	KLG221HG	KLG222HG
Radyan / Burner	3	4	5
Genişlik / Width	21,7"	21,7"	21,7"
Derinlik / Depth	27,6"	27,6"	27,6"
Yükseklik / Height	44,1"	50,6"	57,1"
Ağırlık / Weight	66 lbs	77 lbs	88 lbs
Gerilim / Voltage*	230 V / 50 Hz	230 V / 50 Hz	230 V / 50 Hz
Kapasite / Capacity	90 lbs	130 lbs	175 lbs
Tüketim / Consumption	35,88 ft ³ /h	47,85 ft ³ /h	59,82 ft ³ /h
Güç / Power	33270 BTU	44360 BTU	55450 BTU

* Şehir gerilimi 110 V olan ülkelere gönderilen ürünler 110 V ayarlı olarak üretilmektedir.

* Products sent to countries with 110 V city voltage are produced with 110 V adjustment.

ELEKTRİKLİ, ÜSTTEN MOTORLU, CAMLI
ELECTRICAL, TOP MOTOR, WITH GLASS



KLG231



TR

- ROBAX Color S termal camlı
- 12 mm genişliğinde içi dolu, paslanmaz kılıç ve et sacı
- Talebe göre opsiyonel sağ ve sol rüzgarlık kanat takımı
- İki kademeli pişirme sıcaklığı (Düşük & Yüksek)
- Üstten motorlu (Çift yönde dönebilme özelliği)
- Ayarlanabilir döner şişi
- Paslanmaz çelik gövdeli
- Hijyenik, emniyetli ve uzun ömürlü

EN

- ROBAX Color S thermal glass
- 12 mm solid and stainless skewer and skewer plate
- Optional wind wings set (Left & Right)
- Two different level cooking temperature (Low & High)
- Motor at top (Reversible motor)
- Adjustable skewer
- Stainless steel body
- Hygienic, safe and long lasting

EU ÜRÜN KODU / PRODUCT CODE	KLG235	KLG230	KLG231	KLG232
Radyan / Burner	1	3	4	5
Genişlik / Width	330 mm	550 mm	550 mm	550 mm
Derinlik / Depth	295 mm	700 mm	700 mm	700 mm
Yükseklik / Height	630 mm	960 mm	1120 mm	1285 mm
Ağırlık / Weight	15 kg	25 kg	30 kg	35 kg
Gerilim / Voltage	230 V / 50 Hz	400 V / 50 Hz	400 V / 50 Hz	400 V / 50 Hz
Kapasite / Capacity	5 kg	40 kg	60 kg	80 kg
Güç / Power	1,80 kW	5,40 kW	7,20 kW	9,00 kW
Fiyat / Price				

US ÜRÜN KODU / PRODUCT CODE	KLG235	KLG230	KLG231	KLG232
Radyan / Burner	1	3	4	5
Genişlik / Width	13"	21,7"	21,7"	21,7"
Derinlik / Depth	11,6"	27,6"	27,6"	27,6"
Yükseklik / Height	24,8"	37,8"	44,1"	50,6"
Ağırlık / Weight	33 lbs	55 lbs	66 lbs	77 lbs
Gerilim / Voltage*	230 V / 50 Hz	400 V / 50 Hz	400 V / 50 Hz	400 V / 50 Hz
Kapasite / Capacity	11 lbs	90 lbs	130 lbs	175 lbs
Güç / Power	6140 BTU	18420 BTU	24570 BTU	30710 BTU

*Bulduğunuz bölgedeki trifaz gerilimi tablodaki değerden farklıysa bizimle iletişime geçebilirsiniz.

*If the three-phase voltage in your region is different from the value in the table, you can contact us.

ELEKTRİKLİ, ÜSTTEN MOTORLU, CAMLI, HAREKETLİ GÖVDE
ELECTRICAL, TOP MOTOR, WITH GLASS, MOVING BODY

TR

- ROBAX Color S termal camlı
- 12 mm genişliğinde içi dolu, paslanmaz kılıç ve et sacı
- İki kademeli pişirme sıcaklığı (Düşük & Yüksek)
- Üstten motorlu (Çift yönde dönebilme özelliği)
- Gövde hareketli (Isıtıcılar döner etine yaklaşır)
- Ayarlanabilir döner şişi
- Paslanmaz çelik gövdeli
- Hijyenik, emniyetli ve uzun ömürlü

EN

- ROBAX Color S thermal glass
- 12 mm solid and stainless skewer and skewer plate
- Two different level cooking temperature (Low & High)
- Motor at top (Reversible motor)
- Moving body (Burners can come close to doner meat)
- Adjustable skewer
- Stainless steel body
- Hygienic, safe and long lasting



KLG231HG



EU ÜRÜN KODU / PRODUCT CODE	KLG230HG	KLG231HG	KLG232HG
Radyan / Burner	3	4	5
Genişlik / Width	550 mm	550 mm	550 mm
Derinlik / Depth	700 mm	700 mm	700 mm
Yükseklik / Height	960 mm	1120 mm	1285 mm
Ağırlık / Weight	25 kg	30 kg	35 kg
Gerilim / Voltage	400 V / 50 Hz	400 V / 50 Hz	400 V / 50 Hz
Kapasite / Capacity	40 kg	60 kg	80 kg
Güç / Power	5,40 kW	7,20 kW	9,00 kW
Fiyat / Price			

US ÜRÜN KODU / PRODUCT CODE	KLG230HG	KLG231HG	KLG232HG
Radyan / Burner	3	4	5
Genişlik / Width	21,7"	21,7"	21,7"
Derinlik / Depth	27,6"	27,6"	27,6"
Yükseklik / Height	37,8"	44,1"	50,6"
Ağırlık / Weight	55 lbs	66 lbs	77 lbs
Gerilim / Voltage*	400 V / 50 Hz	400 V / 50 Hz	400 V / 50 Hz
Kapasite / Capacity	90 lbs	130 lbs	175 lbs
Güç / Power	18420 BTU	24570 BTU	30710 BTU

*Bulduğunuz bölgedeki trifaz gerilimi tablodaki değerden farklıysa bizimle iletişime geçebilirsiniz.
*If the three-phase voltage in your region is different from the value in the table, you can contact us.

GAZLI, MOTORSUZ
GAS, WITHOUT MOTOR



KL141



TR

- Doğalgaz veya Propan (LPG)
- 12 mm genişliğinde içi dolu, paslanmaz kılıç ve et sacı
- Talebe göre opsiyonel sağ ve sol rüzgarlık kanat takımı
- Emniyet ventilli gaz valfi
- Ayarlanabilir döner şişi
- Paslanmaz çelik gövdeli
- AISI-310S Cr-Ni radyan koruma teli
- Hijyenik, emniyetli ve uzun ömürlü
- 3+3 dik radyanlı model seçeneği

EN

- Natural gas or Propan (LPG)
- 12mm solid and stainless skewer and skewer plate
- Optional wind wings set (Left & Right)
- Equipped with safety gas valve
- Adjustable skewer
- Stainless steel body
- AISI-310 S Cr-Ni burner cover
- Hygienic, safe and long lasting
- Optional 3+3 vertical burner model.

ÜRÜN KODU / PRODUCT CODE	KL143	KL140	KL141	KL142	KL146
Radyan / Burner	3 (Dik / Vertical)	3	4	5	6
Genişlik / Width	550 mm	550 mm	550 mm	550 mm	550 mm
Derinlik / Depth	695 mm	670 mm	670 mm	670 mm	670 mm
Yükseklik / Height	910 mm	750 mm	910 mm	1075 mm	1240 mm
Ağırlık / Weight	27 kg	22 kg	27 kg	32 kg	37 kg
Kapasite / Capacity	40 kg	40 kg	60 kg	80 kg	100 kg
Tüketim / Consumption	1,016 m ³ /h	1,016 m ³ /h	1,355 m ³ /h	1,694 m ³ /h	2,053 m ³ /h
Güç / Power	9,75 kW	9,75 kW	13,00 kW	16,25 kW	19,50 kW
Fiyat / Price					

ÜRÜN KODU / PRODUCT CODE	KL143	KL140	KL141	KL142	KL146
Radyan / Burner	3 (Dik / Vertical)	3	4	5	6
Genişlik / Width	21,7"	21,7"	21,7"	21,7"	21,7"
Derinlik / Depth	26,4"	26,4"	26,4"	26,4"	26,4"
Yükseklik / Height	35,8"	29,5"	35,8"	42,3"	48,8"
Ağırlık / Weight	59 lbs	49 lbs	59 lbs	70 lbs	81 lbs
Kapasite / Capacity	90 lbs	90 lbs	130 lbs	175 lbs	220 lbs
Tüketim / Consumption	35,88 ft ³ /h	35,88 ft ³ /h	47,85 ft ³ /h	59,82 ft ³ /h	72,5 ft ³ /h
Güç / Power	55450 BTU	33270 BTU	33270 BTU	44360 BTU	66530 BTU

**GAZLI, MOTORSUZ, V MODEL
GAS, WITHOUT MOTOR, V MODEL**



KL142V

TR

- Doğalgaz veya Propan (LPG)
- 12 mm genişliğinde içi dolu, paslanmaz kılıç ve et sacı
- Talebe göre opsiyonel sağ ve sol rüzgarlık kanat takımı
- Emniyet ventilli gaz valfi
- Ayarlanabilir döner şişi
- Paslanmaz çelik gövdeli
- AISI-310S Cr-Ni radyan koruma teli
- Hijyenik, emniyetli ve uzun ömürlü
- 3+3 dik radyanlı model seçeneği

EN

- Natural gas or Propan (LPG)
- 12mm solid and stainless skewer and skewer plate
- Optional wind wings set (Left & Right)
- Equipped with safety gas valve
- Adjustable skewer
- Stainless steel body
- AISI-310 S Cr-Ni burner cover
- Hygienic, safe and long lasting
- Optional 3+3 vertical burner model.



EU ÜRÜN KODU / PRODUCT CODE	KL143V	KL141V	KL142V	KL146V
Radyan / Burner	3+3 (Dik / Vertical)	4+4	5+5	6+6
Genişlik / Width	750 mm	900 mm	900 mm	900 mm
Derinlik / Depth	875 mm	965 mm	965 mm	1110 mm
Yükseklik / Height	920 mm	920 mm	1085 mm	1375 mm
Ağırlık / Weight	50 kg	45 kg	50 kg	55 kg
Kapasite / Capacity	70 kg	90 kg	120 kg	150 kg
Tüketim / Consumption	2,033 m ³ /h	2,710 m ³ /h	3,388 m ³ /h	4,066 m ³ /h
Güç / Power	19,50 kW	26,00 kW	32,50 kW	39,00 kW
Fiyat / Price				

US ÜRÜN KODU / PRODUCT CODE	KL143V	KL141V	KL142V	KL146V
Radyan / Burner	3+3 (Dik / Vertical)	4+4	5+5	6+6
Genişlik / Width	29,5"	35,4"	35,4"	35,4"
Derinlik / Depth	34,4"	38"	38"	43,7"
Yükseklik / Height	36,2"	36,2"	42,7"	54,1"
Ağırlık / Weight	110 lbs	99 lbs	110 lbs	121 lbs
Kapasite / Capacity	155 lbs	200 lbs	265 lbs	330 lbs
Tüketim / Consumption	71,79 ft ³ /h	95,7 ft ³ /h	119,65 ft ³ /h	143,59 ft ³ /h
Güç / Power	66530 BTU	88710 BTU	110890 BTU	133070 BTU

**ELEKTRİKLİ, MOTORSUZ, CAMLI
ELECTRICAL, WITHOUT MOTOR, WITH GLASS****KL161****TR**

- ROBAX Color S termal camlı
- 12 mm genişliğinde içi dolu, paslanmaz kılıç ve et sacı
- Talebe göre opsiyonel sağ ve sol rüzgarlık kanat takımı
- İki kademeli pişirme sıcaklığı (Düşük & Yüksek)
- Ayarlanabilir döner şişi
- Paslanmaz çelik gövdeli
- Hijyenik, emniyetli ve uzun ömürlü

EN

- ROBAX Color S thermal glass
- 12 mm solid and stainless skewer and skewer plate
- Optional wind wings set (Left & Right)
- Two different level cooking temperature (Low & High)
- Adjustable skewer
- Stainless steel body
- Hygienic, safe and long lasting

EU ÜRÜN KODU / PRODUCT CODE	KL160	KL161	KL162
Radyan / Burner	3	4	5
Genişlik / Width	550 mm	550 mm	550 mm
Derinlik / Depth	700 mm	700 mm	700 mm
Yükseklik / Height	750 mm	910 mm	1075 mm
Ağırlık / Weight	24 kg	30 kg	37 kg
Gerilim / Voltage	400V 50Hz	400V 50Hz	400V 50Hz
Kapasite / Capacity	40 kg	60 kg	80 kg
Güç / Power	5,4 kW	7,2 kW	9 kW
Fiyat / Price			

US ÜRÜN KODU / PRODUCT CODE	KL160	KL161	KL162
Radyan / Burner	3	4	5
Genişlik / Width	21,6"	21,6"	21,6"
Derinlik / Depth	27,5"	27,5"	27,5"
Yükseklik / Height	29,5"	35,8"	42,3"
Ağırlık / Weight	65 lbs	75 lbs	90 lbs
Gerilim / Voltage*	400V 50Hz	400V 50Hz	400V 50Hz
Kapasite / Capacity	90 lbs	130 lbs	175 lbs
Güç / Power	18420 BTU	24570 BTU	30710 BTU

*Bulduğunuz bölgedeki trifaz gerilimi tablodaki değerden farklıysa bizimle iletişime geçebilirsiniz.
*If the three-phase voltage in your region is different from the value in the table, you can contact us.

ELEKTRİKLİ, MOTORSUZ, CAMLI, V MODEL
ELECTRICAL, WITHOUT MOTOR, WITH GLASS, V MODEL

KLG162V

TR

- ROBAX Color S termal camlı
- 12 mm genişliğinde içi dolu, paslanmaz kılıç ve et sacı
- Talebe göre opsiyonel sağ ve sol rüzgarlık kanat takımı
- İki kademeli pişirme sıcaklığı (Düşük & Yüksek)
- Ayarlanabilir döner şişi
- Paslanmaz çelik gövdeli
- Hijyenik, emniyetli ve uzun ömürlü

EN

- ROBAX Color S thermal glass
- 12 mm solid and stainless skewer and skewer plate
- Optional wind wings set (Left & Right)
- Two different level cooking temperature (Low & High)
- Adjustable skewer
- Stainless steel body
- Hygienic, safe and long lasting



EU ÜRÜN KODU / PRODUCT CODE	KLG161V	KLG162V
Radyan / Burner	4+4	5+5
Genişlik / Width	900 mm	900 mm
Derinlik / Depth	965 mm	965 mm
Yükseklik / Height	920 mm	1085 mm
Ağırlık / Weight	66 kg	73 kg
Gerilim / Voltage	400 V / 50 Hz	400 V / 50 Hz
Kapasite / Capacity	90 kg	120 kg
Güç / Power	14,40 kW	18,00 kW
Fiyat / Price		

US ÜRÜN KODU / PRODUCT CODE	KLG161V	KLG162V
Radyan / Burner	4+4	5+5
Genişlik / Width	35,4"	35,4"
Derinlik / Depth	38"	38"
Yükseklik / Height	36,2"	42,7"
Ağırlık / Weight	145 lbs	161 lbs
Gerilim / Voltage*	400 V / 50 Hz	400 V / 50 Hz
Kapasite / Capacity	200 lbs	265 lbs
Güç / Power	49130 BTU	61420 BTU

*Bulduğunuz bölgedeki trifaz gerilimi tablodaki değerden farklıysa bizimle iletişime geçebilirsiniz.
*If the three-phase voltage in your region is different from the value in the table, you can contact us.

**DÖNER KESME BIÇAĞI, ELEKTRİKLİ
DONER SLICER, ELECTRICAL****KLG32****TR**

- Hızlı, verimli ve temiz kesim
- Kolay kesim ayarı
- Emniyetli ve rahat kullanım
- Plastik gövde
- Hijyenik ve uzun ömürlü
- 5000 devir/dakika

EN

- Quick, efficient and clean cut
- Easy slice thickness control
- Safe and easy handling
- Plastic housing
- Hygienic and long lasting
- 5000 RPM

ÜRÜN KODU / PRODUCT CODE	KLG 32
Dairesel Bıçak Çapı / Circular Blade Diameter	80 mm
Fiyat / Price	

**DÖNER KÜREĞİ
DONER SHOVEL****KLG26****TR**

- AISI 304 paslanmaz çelik
- Bakalit kulp

EN

- AISI 304 stainless steel
- Bakalite handle

ÜRÜN KODU / PRODUCT CODE	KLG 26
Çap / Diameter	260 mm
Fiyat / Price	

**DÖNER OCAĞI RÜZGARLIK TAKIMI
DONER KEBAB GRILL WIND WINGS SET****ÜRÜN ADI
PRODUCT NAME**Döner Ocağı Rüzgarlık Takımı
Doner Kebab Grill Wind Wings Set**DÖNER OCAĞI SÜZGEÇ
DONER KEBAB GRILL STRAINER****ÜRÜN ADI
PRODUCT NAME**Döner Ocağı Süzgeç
Doner Kebab Grill Strainer

DÖNER TAŞIMA LİFTİ
MEAT LIFTING TROLLEY

KLGMLT

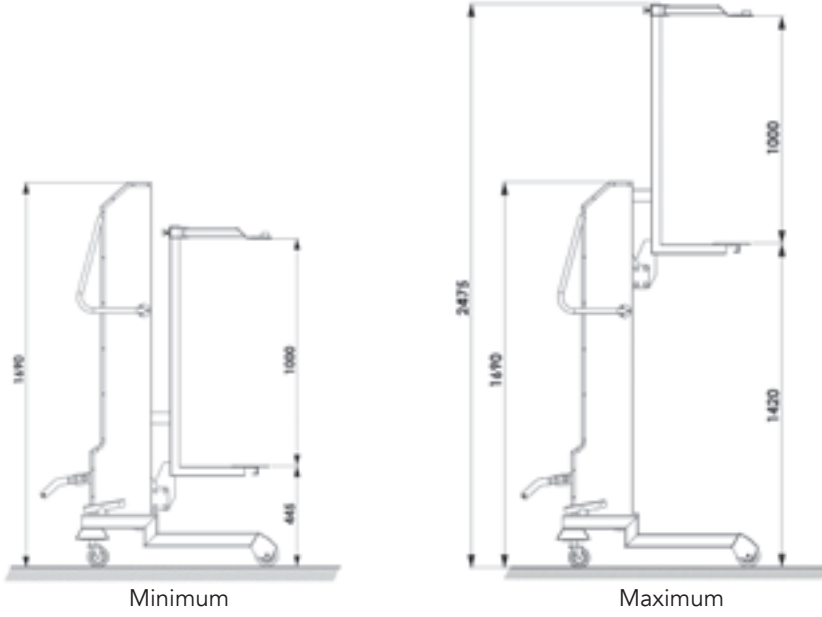

PRODUCT CODE ÜRÜN KODU	PRODUCT NAME ÜRÜN ADI	Dimension (W x D x H) Ürün Ölçüsü (G x D x Y)	Kapasite Capacity	Net Weight Net Ağırlık	Price Fiyat
KLGMLT	Döner Taşıma Lifti Meat Lifting Trolley	800 x 560 x 1690 mm	400 kg	100 kg	

DÖNER ROBOTU STANDI
DONER ROBOT STAND

RODOCS

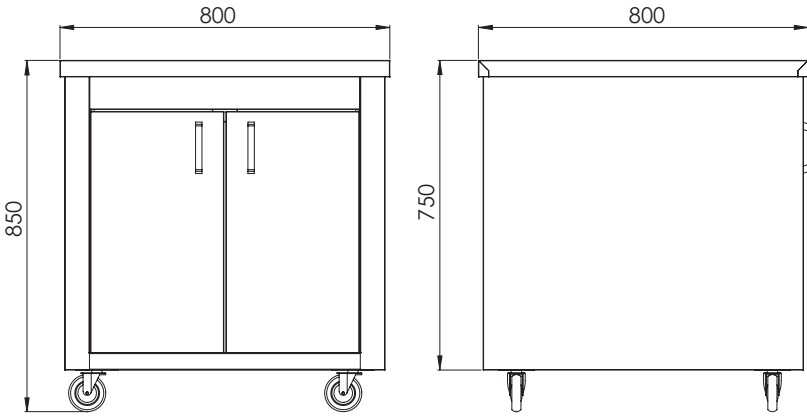

PRODUCT CODE ÜRÜN KODU	PRODUCT NAME ÜRÜN ADI	Dimension (W x D x H) Ürün Ölçüsü (G x D x Y)	Net Weight Net Ağırlık	Price Fiyat
RODOCS	Döner Robotu Standı Doner Robot Stand	800 x 800 x 852 mm	48 kg	

ELEKTRİKLİ ANALOG KONTROL PİZZA FIRINLARI

ELECTRICAL ANALOG CONTROL PIZZA OVENS



Elektrikli Analog Kontrol Pizza Fırınları / Electrical Analog Control Pizza Ovens

62 x 62 cm

72 x 72 cm

62 x 93 cm Derin Model / Deep Model

72 x 108 cm Derin Model / Deep Model

93 x 62 cm Geniş Model / Wide Model

108 x 72 cm Geniş Model / Wide Model

108 x 108 cm

**ANALOG KONTROL, 62x62 cm
ANALOG CONTROL, 62x62 cm**

Tek Katlı / Single Deck



E4301A

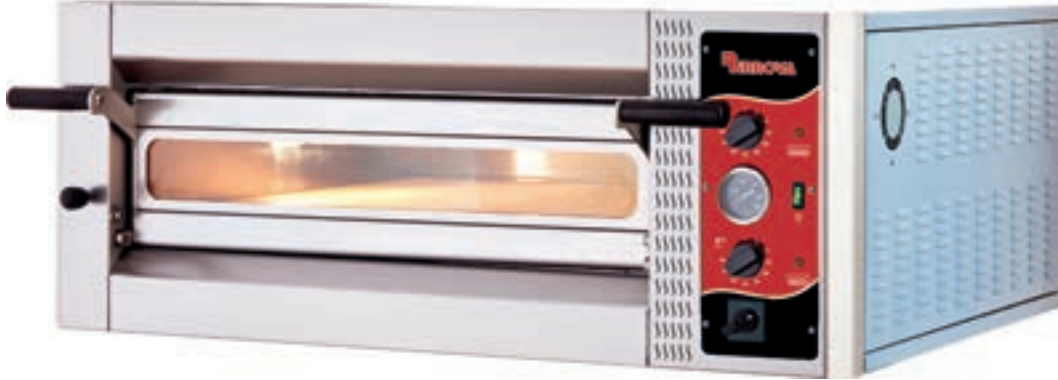

Çift Katlı / Double Decks



E4302A

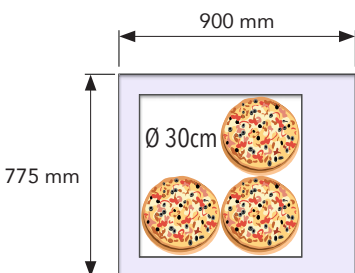

ÜRÜN KODU / PRODUCT CODE	E4301A	E4302A
Model / Model	62 x 62 cm	62 x 62 cm
Piştirme Kapasitesi / Baking Capacity	4 Pizza (Ø 30 cm)	4+4 Pizza (Ø 30 cm)
İç Ölçü (G x D x Y) / Internal Dimension (W x D x H)	620 x 620 x 130 mm	620 x 620 x 130 mm
Dış Ölçü (G x D x Y) / External Dimension (W x D x H)	900 x 775 x 412 mm	900 x 775 x 740 mm
Net Ağırlık / Net Weight	72 kg	129 kg
Gerilim / Voltage	400 V	400 V
Güç / Power	4,2 kW	8,4 kW
Maksimum Piştirme Sıcaklığı / Maximum Baking Temperature	400 °C	400 °C
Fiyat / Price		

ANALOG KONTROL, 72x72 cm
ANALOG CONTROL, 72x72 cm**E4351A**

Tek Katlı / Single Deck

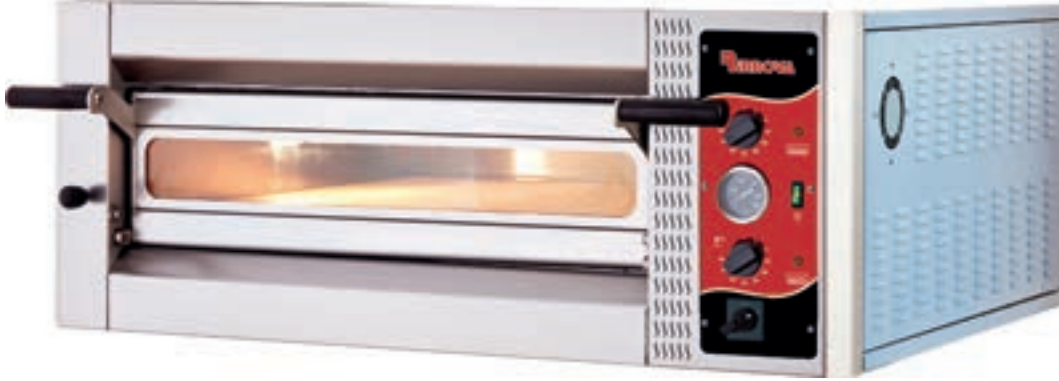
**E4352A**

Çift Katlı / Double Decks



ÜRÜN KODU / PRODUCT CODE	E4351A	E4352A
Model / Model	72 x 72 cm	72 x 72 cm
Piştirme Kapasitesi / Baking Capacity	4 Pizza (Ø 35 cm)	4+4 Pizza (Ø 35 cm)
İç Ölçü (G x D x Y) / Internal Dimension (W x D x H)	720 x 720 x 130 mm	720 x 720 x 130 mm
Dış Ölçü (G x D x Y) / External Dimension (W x D x H)	1000 x 875 x 412 mm	1000 x 875 x 740 mm
Net Ağırlık / Net Weight	76 kg	137 kg
Gerilim / Voltage	400 V	400 V
Güç / Power	5,1 kW	10,2 kW
Maksimum Piştirme Sıcaklığı / Maximum Baking Temperature	400 °C	400 °C
Fiyat / Price		

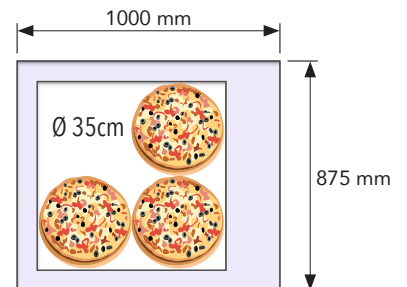

**ANALOG KONTROL, 62x93 cm, DERİN MODEL
ANALOG CONTROL, 62x93 cm, DEEP MODEL**

Tek Katlı / Single Deck



E6301DA



Çift Katlı / Double Decks



E6302DA

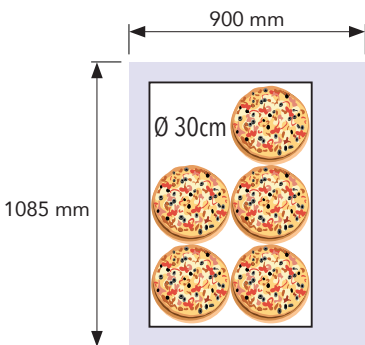

ÜRÜN KODU / PRODUCT CODE	E6301DA	E6302DA
Model / Model	62 x 93 cm Derin Model / Deep Model	62 x 93 cm Derin Model / Deep Model
Piştirme Kapasitesi / Baking Capacity	6 Pizza (Ø 30 cm)	6+6 Pizza (Ø 30 cm)
İç Ölçü (G x D x Y) / Internal Dimension (W x D x H)	620 x 930 x 130 mm	620 x 930 x 130 mm
Dış Ölçü (G x D x Y) / External Dimension (W x D x H)	900 x 1085 x 412 mm	900 x 1085 x 740 mm
Net Ağırlık / Net Weight	96 kg	167 kg
Gerilim / Voltage	400 V	400 V
Güç / Power	7,2 kW	14,4 kW
Maksimum Piştirme Sıcaklığı / Maximum Baking Temperature	400 °C	400 °C
Fiyat / Price		

**ANALOG KONTROL, 72x108 cm, DERİN MODEL
ANALOG CONTROL, 72x108 cm, DEEP MODEL****E6351DA**

Tek Katlı / Single Deck

**E6352DA**

Çift Katlı / Double Decks



ÜRÜN KODU / PRODUCT CODE	E6351DA	E6352DA
Model / Model	72 x 108 cm Derin Model / Deep Model	72 x 108 cm Derin Model / Deep Model
Piştirme Kapasitesi / Baking Capacity	6 Pizza (Ø 35 cm)	6+6 Pizza (Ø 35 cm)
İç Ölçü (G x D x Y) / Internal Dimension (W x D x H)	720 x 1080 x 130 mm	720 x 1080 x 130 mm
Dış Ölçü (G x D x Y) / External Dimension (W x D x H)	1000 x 1235 x 412 mm	1000 x 1235 x 740 mm
Net Ağırlık / Net Weight	100 kg	172 kg
Gerilim / Voltage	400 V	400 V
Güç / Power	7,8 kW	15,6 kW
Maksimum Piştirme Sıcaklığı / Maximum Baking Temperature	400 °C	400 °C
Fiyat / Price		

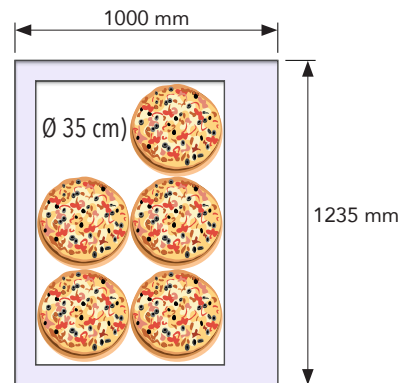

**ANALOG KONTROL, 93x62 cm GENİŞ MODEL
ANALOG CONTROL, 93x62 cm WIDE MODEL**

Tek Katlı / Single Deck



E6301WA



Çift Katlı / Double Decks



E6302WA

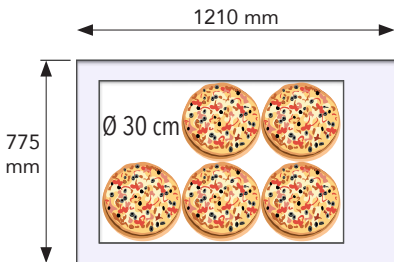

ÜRÜN KODU / PRODUCT CODE	E6301WA	E6302WA
Model / Model	93 x 62 cm Geniş Model / Wide Model	93 x 62 cm Geniş Model / Wide Model
Piştirme Kapasitesi / Baking Capacity	6 Pizza (Ø 30 cm)	6+6 Pizza (Ø 30 cm)
İç Ölçü (G x D x Y) / Internal Dimension (W x D x H)	930 x 620 x 130 mm	930 x 620 x 130 mm
Dış Ölçü (G x D x Y) / External Dimension (W x D x H)	1210 x 775 x 412 mm	1210 x 775 x 740 mm
Net Ağırlık / Net Weight	100 kg	171 kg
Gerilim / Voltage	400 V	400 V
Güç / Power	7,8 kW	15,6 kW
Maksimum Piştirme Sıcaklığı / Maximum Baking Temperature	400 °C	400 °C
Fiyat / Price		

ANALOG KONTROL, 108x72 cm GENİŞ MODEL
ANALOG CONTROL, 108x72 cm WIDE MODEL**E6351WA**

Tek Katlı / Single Deck

**E6352WA**

Çift Katlı / Double Decks



ÜRÜN KODU / PRODUCT CODE	E6351WA	E6352WA
Model / Model	108 x 72 cm Geniş Model / Wide Model	108 x 72 cm Geniş Model / Wide Model
Piştirme Kapasitesi / Baking Capacity	6 Pizza (Ø 35 cm)	6+6 Pizza (Ø 35 cm)
İç Ölçü (G x D x Y) / Internal Dimension (W x D x H)	1080 x 720 x 130 mm	1080 x 720 x 130 mm
Dış Ölçü (G x D x Y) / External Dimension (W x D x H)	1360 x 875 x 412 mm	1360 x 875 x 740 mm
Net Ağırlık / Net Weight	104 kg	175 kg
Gerilim / Voltage	400 V	400 V
Güç / Power	10,0 kW	20,0 kW
Maksimum Piştirme Sıcaklığı / Maximum Baking Temperature	400 °C	400 °C
Fiyat / Price		

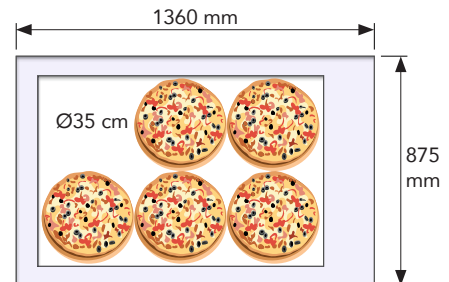

ANALOG KONTROL, 108x108 cm
ANALOG CONTROL, 108x108 cm

Tek Katlı / Single Deck



E9351A



Çift Katlı / Double Decks



E9352A

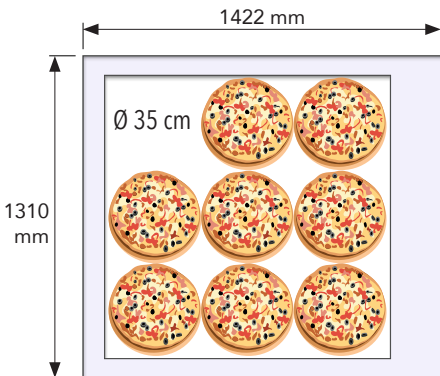

ÜRÜN KODU / PRODUCT CODE	E9351A	E9352A
Model / Model	108 x 108 cm	108 x 108 cm
Piştirme Kapasitesi / Baking Capacity	9 Pizza (Ø 35 cm)	9+9 Pizza (Ø 35 cm)
İç Ölçü (G x D x Y) / Internal Dimension (W x D x H)	1080 x 1080 x 125 mm	1080 x 1080 x 125 mm
Dış Ölçü (G x D x Y) / External Dimension (W x D x H)	1422 x 1310 x 412 mm	1422 x 1310 x 740 mm
Net Ağırlık / Net Weight	100 kg	200 kg
Gerilim / Voltage	400 V	400 V
Güç / Power	13,2 kW	26,4 kW
Maksimum Piştirme Sıcaklığı / Maximum Baking Temperature	400 °C	400 °C
Fiyat / Price		

ELEKTRİKLİ BASIC PİZZA FIRINLARI

ELECTRICAL BASIC PIZZA OVENS



ELEKTRİKLİ BASIC PİZZA FIRINLARI / ELECTRICAL BASIC PIZZA OVENS

Analog Kontrol, Basic Model / Analog Control Basic Model

62 x 62 cm

68 x 68 cm

93 x 62 cm Geniş Model / Wide Model

Analog Kontrol, Taş Kaplamalı Model / Analog Control, Stone Covered Model

72 x 72 cm

ANALOG KONTROL, 62x62 cm, BASIC MODEL
ANALOG CONTROL, 62x62 cm, BASIC MODEL

Tek Katlı / Single Deck



E4301AB



Çift Katlı / Double Decks



E4302AB

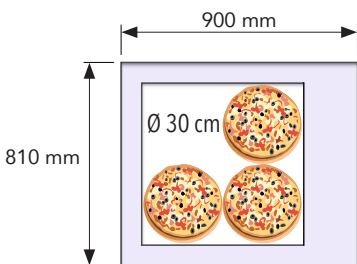

ÜRÜN KODU / PRODUCT CODE	E4301AB	E4302AB
Model / Model	62 x 62 cm BASIC	62 x 62 cm BASIC
Piştirme Kapasitesi / Baking Capacity	4 Pizza (Ø 30 cm)	4+4 Pizza (Ø 30 cm)
İç Ölçü (G x D x Y) / Internal Dimension (W x D x H)	615 x 635 x 150 mm	615 x 635 x 150 mm
Dış Ölçü (G x D x Y) / External Dimension (W x D x H)	900 x 810 x 405 mm	900 x 810 x 765 mm
Net Ağırlık / Net Weight	65 kg	121 kg
Gerilim / Voltage	400 V	400 V
Güç / Power	5,2 kW	10,4 kW
Maksimum Piştirme Sıcaklığı / Maximum Baking Temperature	400°C	400°C
Fiyat / Price		

**ANALOG KONTROL, 68x68 cm, BASIC MODEL
ANALOG CONTROL, 68x68 cm, BASIC MODEL****E4331AB**

Tek Katlı / Single Deck

**E4332AB**

Çift Katlı / Double Decks



ÜRÜN KODU / PRODUCT CODE	E4331AB	E4332AB
Model / Model	68 x 68 cm BASIC	68 x 68 cm BASIC
Piştirme Kapasitesi / Baking Capacity	4 Pizza (Ø 33 cm)	4+4 Pizza (Ø 33 cm)
İç Ölçü (G x D x Y) / Internal Dimension (W x D x H)	675 x 700 x 150 mm	675 x 700 x 150 mm
Dış Ölçü (G x D x Y) / External Dimension (W x D x H)	960 x 870 x 405 mm	960 x 870 x 765 mm
Net Ağırlık / Net Weight	75 kg	140 kg
Gerilim / Voltage	400 V	400 V
Güç / Power	5,6 kW	11 kW
Maksimum Piştirme Sıcaklığı / Maximum Baking Temperature	400°C	400°C
Fiyat / Price		

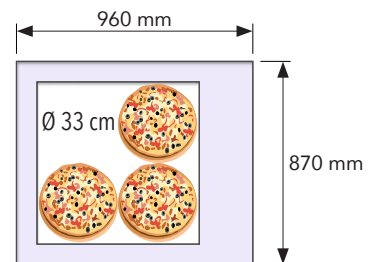

ANALOG KONTROL, 93x62 cm, BASIC MODEL
ANALOG CONTROL, 93x62 cm, BASIC MODEL

Tek Katlı / Single Deck



E6301WAB



Çift Katlı / Double Decks



E6302WAB

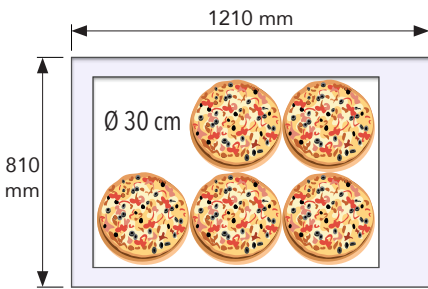

ÜRÜN KODU / PRODUCT CODE	E6301WAB	E6302WAB
Model / Model	93 x 62 cm BASIC	93 x 62 cm BASIC
Pişirme Kapasitesi / Baking Capacity	6 Pizza (Ø 30 cm)	6+6 Pizza (Ø 30 cm)
İç Ölçü (G x D x Y) / Internal Dimension (W x D x H)	925 x 635 x 150 mm	925 x 635 x 150 mm
Dış Ölçü (G x D x Y) / External Dimension (W x D x H)	1210 x 810 x 405 mm	1210 x 810 x 765 mm
Net Ağırlık / Net Weight	86 kg	162 kg
Gerilim / Voltage	400 V	400 V
Güç / Power	6 kW	12 kW
Maksimum Pişirme Sıcaklığı / Maximum Baking Temperature	400°C	400°C
Fiyat / Price		

**ANALOG KONTROL, 72x72 cm, TAŞ KAPLAMALI MODEL
ANALOG CONTROL, 72x72 cm, STONE COVERED MODEL****E4351AS**

Tek Katlı / Single Deck

**E4352AS**

Çift Katlı / Double Decks

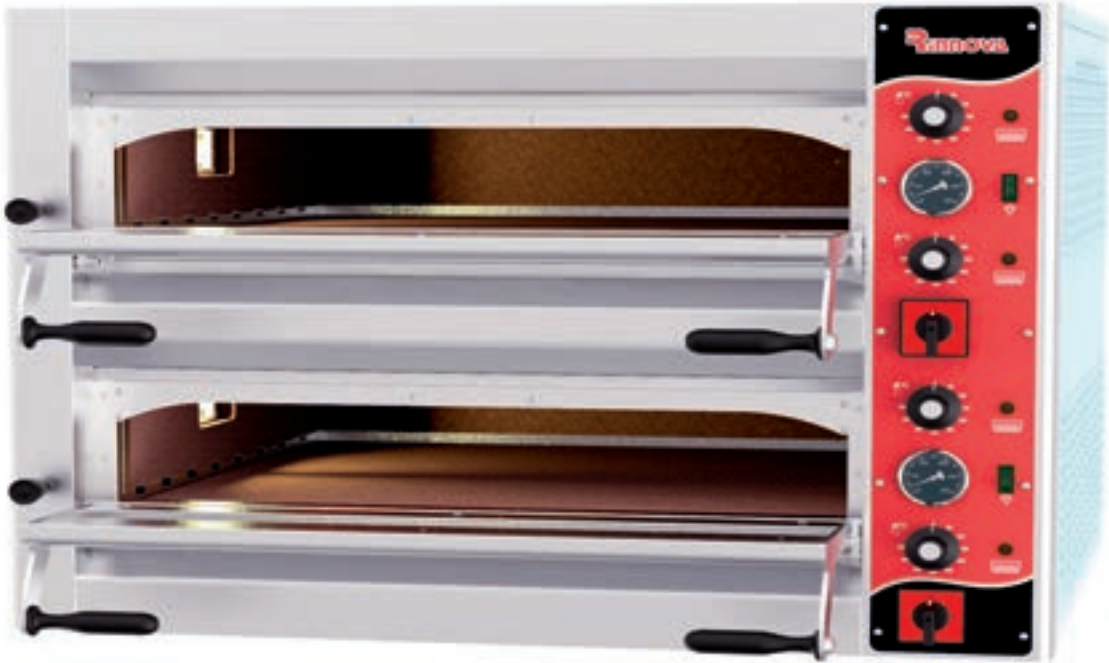

ÜRÜN KODU / PRODUCT CODE	E4351AS	E4352AS
Model / Model	72 x 72 cm	72 x 72 cm
Piştirme Kapasitesi / Baking Capacity	4 Pizza (Ø 35 cm)	4+4 Pizza (Ø 35 cm)
İç Ölçü (G x D x Y) / Internal Dimension (W x D x H)	720 x 740 x 125 mm	720 x 740 x 125 mm
Dış Ölçü (G x D x Y) / External Dimension (W x D x H)	1000 x 875 x 412 mm	1000 x 875 x 740mm
Net Ağırlık / Net Weight	120 kg	181 kg
Gerilim / Voltage	400 V	400 V
Güç / Power	5,1 kW	10,2 kW
Maksimum Piştirme Sıcaklığı / Maximum Baking Temperature	400°C	400°C
Fiyat / Price		

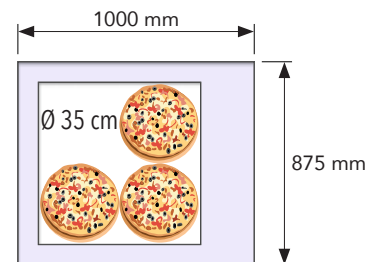

ELEKTRİKLİ DİJİTAL KONTROL PİZZA FIRINLARI

ELECTRICAL DIGITAL CONTROL PIZZA OVENS



Elektrikli Dijital Kontrol Pizza Fırınları / Electrical Digital Control Pizza Ovens

62 x 62 cm

72 x 72 cm

62 x 93 cm Derin Model / Deep Model

72 x 108 cm Derin Model / Deep Model

93 x 62 cm Geniş Model / Wide Model

108 x 72 cm Geniş Model / Wide Model

108 x 108 cm

DİJİTAL PİZZA FIRINI ÖZELLİKLERİ

- Elektronik kontrol sayesinde kullanıcı pişirilecek ürünün özelliğine göre pişirmenin her safhasını kontrol altında tutabilir.
- 10 farklı pişirme programını hafızaya kaydetme kapasitesi vardır. Pizza, lahmacun ya da başka çeşit ürün için belirlemiş olduğunuz ideal pişirme zamanı ve fırın ısısını kolayca P01 (Program 01) ile P10 (Program 10) arasında bir program numarasına kaydedebilir ve istediğiniz zaman kolayca hafızadan çağırabilirsiniz.
- Fırın oda sıcaklığı $\pm 3^{\circ}\text{C}$ hassasiyete göre ayarlanır. Üst ve alt ısıtıcı güçleri ayrı ayrı kontrol edilir ve her ikisi de 0 ile 100 aralığında performansla çalışır.
- Fırına peş peşe çok sayıda pizza atıldığında veya kapağı açık bırakıldığı zaman 3°C lik hassasiyet çok önem taşır. Fırında ısı kaybı 3°C ye ulaştığında ısıtıcılar hemen devreye girer ve fırın ısısını daha önceden programlamış olduğunuz seviyeye hızla çıkarır.
- Fırın iç sıcaklığının istenilen derecenin 25°C ve daha aşağısına düşmesi durumunda, alt ve üst ısıtıcılar 0 olarak ayarlanmadıysa, fırın içi sıcaklığı istenilen dereceye gelene kadar ısıtıcılar %100 performansla çalışır.
- Fırın içi özel dizaynı ve ısı perdeleme sistemi sayesinde fırın içerisindeki ısının homojen olarak dolaşması ve ürünlerin fırının her tarafında eşit pişmesi sağlanmıştır. Ayrıca ısı perdeleme sistemi ile fırın kapağı açıldığı zaman sıcak havanın büyük oranda direkt dışarı kaçması önlenmiş, önemli bir kısmının tekrar fırın içine girmesi ve dolaşımı sağlanmıştır.
- Fırın ön camı fırın için rahatça görülebilmesine imkan verecek şekilde dizayn edilmiştir. Ayrıca fırın ısısını dışarıya iletmeyerek ısı kaybını maksimum seviyede azaltır.
- Fırın ısı izolasyonu her taraftan 80 mm kalınlığında ve yüksek yoğunluklu kaya yünü ile yapılmıştır. Bu sayede çabuk ısınır, geç soğur.
- Fırın baca mekanizması mevcuttur.
- Fırın içi aydınlatma lambası kolay değiştirilebilir ve 500°C ye dayanıklıdır.

DIGITAL PIZZA OVEN FEATURES

- *Electronic control allows you to control all phases of baking process for different kind of foods.*
- *10 different baking program saving capacity. You can adjust ideal baking time and oven temperature easily and save to any program number between P01 (Program 01) to P10 (Program 10) and call saved program from memory any time you want.*
- *The temperature of chamber is adjusted at $\pm 3^{\circ}\text{C}$ accuracy. The upper and lower heater powers are individually controlled and both operate in a range from 0 to 100.*
- *The accuracy of 3°C is very important when you have to leave the oven door open for a long time especially when you bake several pizzas in short time in a row. Under this circumstance, heating resistances start heating as soon as the heat loss of the oven is 3°C and brings the oven heat quickly, up to your pre-set heat level.*
- *If the chamber temperature of the oven decrease 25°C or more, the heaters will run at 100% performance until the chamber temperature is at the desired temperature, if the bottom and top heaters are not set to 0.*
- *Foods could be baked equally at every part of oven as a result of homogeneous heat transfer all around the oven chamber owing to oven's interior special design and Heat Blocking system. When oven door is open, Heat Blocking system prevents most of the sudden heat burst out through oven door and force them back to inside of oven chamber.*
- *Door glass of oven is specially designed to allow user to see inside of oven chamber easily. It also reduces heat loss at maximum degree by not conveying the heat.*
- *Insulation of oven was made with 80 mm. High density Rock wool by covering all around the oven chamber. Due to good insulation, oven heats up quickly and cools down slowly.*
- *Exhaust system for baking steam is exist.*
- *Oven light is heat resistant up to 500°C and bulb could be replaced easily through oven chamber.*

**DİJİTAL KONTROL, 62x62 cm
DIGITAL CONTROL, 62x62 cm**

Tek Katlı / Single Deck



E4301



Çift Katlı / Double Decks



E4302

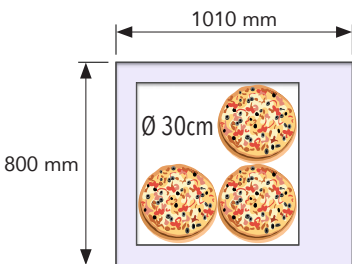

ÜRÜN KODU / PRODUCT CODE	E4301	E4302
Model / Model	62 x 62 cm	62 x 62 cm
Piştirme Kapasitesi / Baking Capacity	4 Pizza (Ø 30 cm)	4+4 Pizza (Ø 30 cm)
İç Ölçü (G x D x Y) / Internal Dimension (W x D x H)	620 x 620 x 130 mm	620 x 620 x 130 mm
Dış Ölçü (G x D x Y) / External Dimension (W x D x H)	1010 x 800 x 425 mm	1010 x 800 x 750 mm
Net Ağırlık / Net Weight	90 kg	170 kg
Gerilim / Voltage	400 V	400 V
Güç / Power	4,2 kW	8,4 kW
Maksimum Piştirme Sıcaklığı / Maximum Baking Temperature	400 °C	400 °C
Fiyat / Price		

**DİJİTAL KONTROL, 72x72 cm
DIGITAL CONTROL, 72x72 cm****E4351**

Tek Katlı / Single Deck

**E4352**

Çift Katlı / Double Decks



ÜRÜN KODU / PRODUCT CODE	E4351	E4352
Model / Model	72 x 72 cm	72 x 72 cm
Piştirme Kapasitesi / Baking Capacity	4 Pizza (Ø 35 cm)	4+4 Pizza (Ø 35 cm)
İç Ölçü (G x D x Y) / Internal Dimension (W x D x H)	720 x 720 x 130 mm	720 x 720 x 130 mm
Dış Ölçü (G x D x Y) / External Dimension (W x D x H)	1110 x 900 x 425 mm	1110 x 900 x 750 mm
Net Ağırlık / Net Weight	95 kg	180 kg
Gerilim / Voltage	400 V	400 V
Güç / Power	5,1 kW	10,2 kW
Maksimum Piştirme Sıcaklığı / Maximum Baking Temperature	400 °C	400 °C
Fiyat / Price		

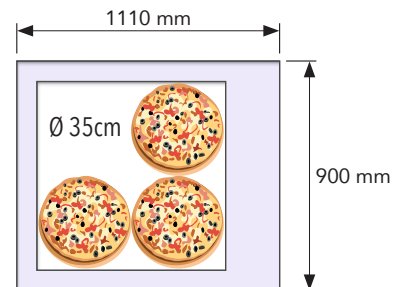

**DİJİTAL KONTROL, 62x93 cm, DERİN MODEL
DIGITAL CONTROL, 62x93 cm, DEEP MODEL**

Tek Katlı / Single Deck



E6301D



Çift Katlı / Double Decks



E6302D

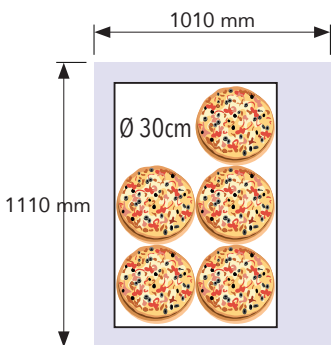

ÜRÜN KODU / PRODUCT CODE	E6301D	E6302D
Model / Model	62 x 93 cm Derin Model / Deep Model	62 x 93 cm Derin Model / Deep Model
Piştirme Kapasitesi / Baking Capacity	6 Pizza (Ø 30 cm)	6+6 Pizza (Ø 30 cm)
İç Ölçü (G x D x Y) / Internal Dimension (W x D x H)	620 x 930 x 130 mm	620 x 930 x 130 mm
Dış Ölçü (G x D x Y) / External Dimension (W x D x H)	1010 x 1110 x 425 mm	1010 x 1110 x 750 mm
Net Ağırlık / Net Weight	120 kg	220 kg
Gerilim / Voltage	400 V	400 V
Güç / Power	7,2 kW	14,4 kW
Maksimum Piştirme Sıcaklığı / Maximum Baking Temperature	400 °C	400 °C
Fiyat / Price		

**DİJİTAL KONTROL, 72x108 cm, DERİN MODEL
DIGITAL CONTROL, 72x108 cm, DEEP MODEL****E6351D**

Tek Katlı / Single Deck

**E6352D**

Çift Katlı / Double Decks



ÜRÜN KODU / PRODUCT CODE	E6351D	E6352D
Model / Model	72 x 108 cm Derin Model / Deep Model	72 x 108 cm Derin Model / Deep Model
Piştirme Kapasitesi / Baking Capacity	6 Pizza (Ø 35 cm)	6+6 Pizza (Ø 35 cm)
İç Ölçü (G x D x Y) / Internal Dimension (W x D x H)	720 x 1080 x 130 mm	720 x 1080 x 130 mm
Dış Ölçü (G x D x Y) / External Dimension (W x D x H)	1110 x 1260 x 425 mm	1110 x 1260 x 750 mm
Net Ağırlık / Net Weight	125 kg	225 kg
Gerilim / Voltage	400 V	400 V
Güç / Power	7,8 kW	15,6 kW
Maksimum Piştirme Sıcaklığı / Maximum Baking Temperature	400 °C	400 °C
Fiyat / Price		

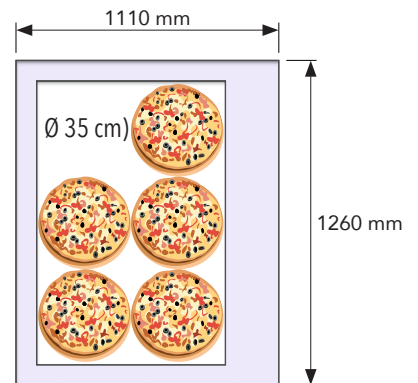

**DİJİTAL KONTROL, 93x62 cm, GENİŞ MODEL
DIGITAL CONTROL, 93x62 cm, WIDE MODEL**

Tek Katlı / Single Deck



E6301W



Çift Katlı / Double Decks



E6302W

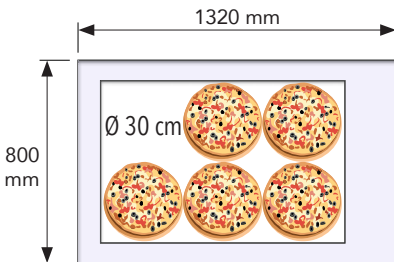

ÜRÜN KODU / PRODUCT CODE	E6301W	E6302W
Model / Model	93 x 62 cm Geniş Model / Wide Model	93 x 62 cm Geniş Model / Wide Model
Piştirme Kapasitesi / Baking Capacity	6 Pizza (Ø 30 cm)	6+6 Pizza (Ø 30 cm)
İç Ölçü (G x D x Y) / Internal Dimension (W x D x H)	930 x 620 x 130 mm	930 x 620 x 130 mm
Dış Ölçü (G x D x Y) / External Dimension (W x D x H)	1320 x 800 x 425 mm	1320 x 800 x 750 mm
Net Ağırlık / Net Weight	125 kg	225 kg
Gerilim / Voltage	400 V	400 V
Güç / Power	7,8 kW	15,6 kW
Maksimum Piştirme Sıcaklığı / Maximum Baking Temperature	400 °C	400 °C
Fiyat / Price		

**DİJİTAL KONTROL, 108x72 cm, GENİŞ MODEL
DIGITAL CONTROL, 108x72 cm, WIDE MODEL****E6351W**

Tek Katlı / Single Deck

**E6352W**

Çift Katlı / Double Decks



ÜRÜN KODU / PRODUCT CODE	E6351W	E6352W
Model / Model	108 x 72 cm Geniş Model / Wide Model	108 x 72 cm Geniş Model / Wide Model
Piştirme Kapasitesi / Baking Capacity	6 Pizza (Ø 35 cm)	6+6 Pizza (Ø 35 cm)
İç Ölçü (G x D x Y) / Internal Dimension (W x D x H)	1080 x 720 x 130 mm	1080 x 720 x 130 mm
Dış Ölçü (G x D x Y) / External Dimension (W x D x H)	1470 x 900 x 425 mm	1470 x 900 x 750 mm
Net Ağırlık / Net Weight	130 kg	230 kg
Gerilim / Voltage	400 V	400 V
Güç / Power	10,0 kW	20,0 kW
Maksimum Piştirme Sıcaklığı / Maximum Baking Temperature	400 °C	400 °C
Fiyat / Price		

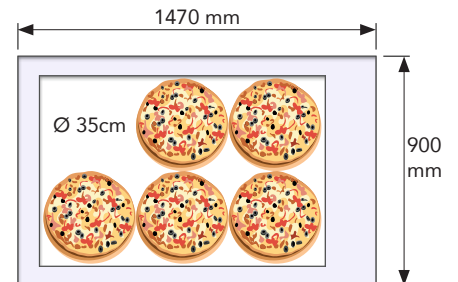

DİJİTAL KONTROL, 108x108 cm
DIGITAL CONTROL, 108x108 cm

Tek Katlı / Single Deck



E9351



Çift Katlı / Double Decks



E9352

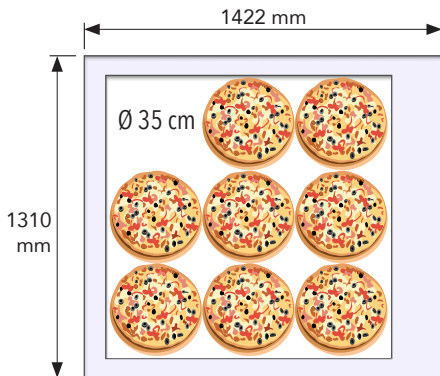

ÜRÜN KODU / PRODUCT CODE	E9351	E9352
Model / Model	108 x 108 cm	108 x 108 cm
Pişirme Kapasitesi / Baking Capacity	9 Pizza (Ø 35 cm)	9+9 Pizza (Ø 35 cm)
İç Ölçü (G x D x Y) / Internal Dimension (W x D x H)	1080 x 1080 x 125 mm	1080 x 1080 x 125 mm
Dış Ölçü (G x D x Y) / External Dimension (W x D x H)	1422 x 1310 x 412 mm	1422 x 1310 x 740 mm
Net Ağırlık / Net Weight	100 kg	200 kg
Gerilim / Voltage	400 V	400 V
Güç / Power	13,2 kW	26,4 kW
Maksimum Pişirme Sıcaklığı / Maximum Baking Temperature	400 °C	400 °C
Fiyat / Price		

GAZLI PİZZA FIRINLARI

GAS PIZZA OVENS



GAZLI PİZZA FIRINLARI / GAS PIZZA OVENS

Analog Kontrol / Analog Control

72 x 72 cm

123 x 92 cm

GAZLI PİZZA FIRINI, 72x72 cm
GAS PIZZA OVEN, 72x72 cm

Çift Katlı / Double Decks



G4352

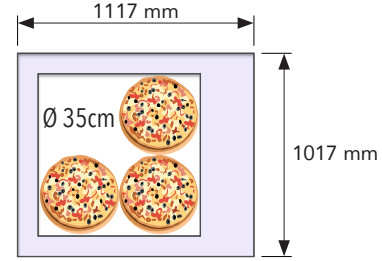

ÜRÜN KODU / PRODUCT CODE	G4352
Model / Model	72 x 72 cm
Piştirme Kapasitesi / Baking Capacity	4+4 Pizza (Ø 35cm)
İç Ölçü (G x D x Y) / Internal Dimension (W x D x H)	720 x 720 x 150 mm
Dış Ölçü (G x D x Y) / External Dimension (W x D x H)	1117 x 1017 x 790 mm
Net Ağırlık / Net Weight	200 kg
Güç / Power	15,5 kW
Maksimum Piştirme Sıcaklığı / Maximum Baking Temperature	450 °C
Fiyat / Price	

GAZLI PİZZA FIRINI, 123x92 cm
GAS PIZZA OVEN, 123x92 cm

Tek Katlı / Single Deck



G12301



ÜRÜN KODU / PRODUCT CODE	G12301
Model / Model	123 x 92 cm
Piştirme Kapasitesi / Baking Capacity	12 Pizza (Ø 30 cm)
İç Ölçü (G x D x Y) / Internal Dimension (W x D x H)	1230 x 920 x 150 mm
Dış Ölçü (G x D x Y) / External Dimension (W x D x H)	1660 x 1185 x 840 mm
Net Ağırlık / Net Weight	200 kg
Güç / Power	28,0 kW
Maksimum Piştirme Sıcaklığı / Maximum Baking Temperature	450 °C
Fiyat / Price	

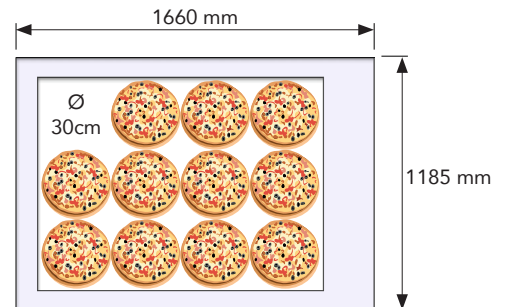

PİZZA FIRINI MASASI / TABLE FOR PIZZA OVEN



ÜRÜN KODU PRODUCT CODE	PİZZA FIRINI KODU PIZZA OVEN CODE	PİZZA MASASI ÖLÇÜLERİ PIZZA TABLE DIMENSIONS (mm)			FİYAT PRICE
		Genişlik Width	Derinlik Depth	Yükseklik Height	
PTE4301A	E4301A	900	709	1100	
PTE4302A	E4302A	900	709	900	
PTE4301	E4301	1010	734	1100	
PTE4302	E4302	1010	734	900	
PTE4351A	E4351A / E4351AS	1000	809	1100	
PTE4352A	E4352A / E4352AS	1000	809	900	
PTE4351	E4351	1110	834	1100	
PTE4352	E4352	1110	834	900	
PTE6301DA	E6301DA	900	1015	1100	
PTE6302DA	E6302DA	900	1015	900	
PTE6301D	E6301D	1010	1040	1100	
PTE6302D	E6302D	1010	1040	900	
PTE6351DA	E6351DA	1000	1165	1100	
PTE6352DA	E6352DA	1000	1165	900	
PTE6351D	E6351D	1110	1190	1100	
PTE6352D	E6352D	1110	1190	900	
PTE6301WA	E6301WA	1210	709	1100	
PTE6302WA	E6302WA	1210	709	900	
PTE6301W	E6301W	1320	734	1100	
PTE6302W	E6302W	1320	734	900	
PTE6351WA	E6351WA	1360	809	1100	
PTE6352WA	E6352WA	1360	809	900	
PTE6351W	E6351W	1470	834	1100	
PTE6352W	E6352W	1470	834	900	
PTE9351	E9351 / E9351A	1422	1245	1100	
PTE9352	E9352 / E9352A	1422	1245	900	
PTE4301AB	E4301AB	900	744	1100	
PTE4302AB	E4302AB	900	744	900	
PTE4331AB	E4331AB	960	804	1100	
PTE4332AB	E4332AB	960	804	900	
PTE6301WAB	E6301WAB	1210	744	1100	
PTE6302WAB	E6302WAB	1210	744	900	
PTG4352	G4352	1097	997	820	
PTG12301	G12301	1660	1185	1100	

PIZZA FIRINI MASASI, ÇEKMECELİ / TABLE FOR PIZZA OVEN, WITH DRAWER



ÜRÜN KODU PRODUCT CODE	PIZZA FIRINI KODU PIZZA OVEN CODE	ÇEKMECELİ PIZZA MASASI ÖLÇÜLERİ PIZZA TABLE WITH DRAWER DIMENSIONS (mm)			FİYAT PRICE
		Genişlik Width	Derinlik Depth	Yükseklik Height	
PTDE4301A	E4301A	900	709	1100	
PTDE4302A	E4302A	900	709	900	
PTDE4301	E4301	1010	734	1100	
PTDE4302	E4302	1010	734	900	
PTDE4351A	E4351A / E4351AS	1000	809	1100	
PTDE4352A	E4352A / E4352AS	1000	809	900	
PTDE4351	E4351	1110	834	1100	
PTDE4352	E4352	1110	834	900	
PTDE6301DA	E6301DA	900	1015	1100	
PTDE6302DA	E6302DA	900	1015	900	
PTDE6301D	E6301D	1010	1040	1100	
PTDE6302D	E6302D	1010	1040	900	
PTDE6351DA	E6351DA	1000	1165	1100	
PTDE6352DA	E6352DA	1000	1165	900	
PTDE6351D	E6351D	1110	1190	1100	
PTDE6352D	E6352D	1110	1190	900	
PTDE6301WA	E6301WA	1210	709	1100	
PTDE6302WA	E6302WA	1210	709	900	
PTDE6301W	E6301W	1320	734	1100	
PTDE6302W	E6302W	1320	734	900	
PTDE6351WA	E6351WA	1360	809	1100	
PTDE6352WA	E6352WA	1360	809	900	
PTDE6351W	E6351W	1470	834	1100	
PTDE6352W	E6352W	1470	834	900	
PTDE9351	E9351 / E9351A	1422	1245	1100	
PTDE9352	E9352 / E9352A	1422	1245	900	
PTDE4301AB	E4301AB	900	744	1100	
PTDE4302AB	E4302AB	900	744	900	
PTDE4331AB	E4331AB	960	804	1100	
PTDE4332AB	E4332AB	960	804	900	
PTDE6301WAB	E6301WAB	1210	744	1100	
PTDE6302WAB	E6302WAB	1210	744	900	
PTDG4352	G4352	1097	997	820	
PTDG12301	G12301	1660	1185	1100	

**PİZZA FIRINI DAVLUMBAZI, MOTORSUZ
HOOD FOR PIZZA OVEN, WITHOUT MOTOR**

ÜRÜN KODU PRODUCT CODE	PİZZA FIRINI KODU PIZZA OVEN CODE	MOTORSUZ DAVLUMBAZ ÖLÇÜLERİ HOOD WITHOUT MOTOR DIMENSIONS (mm)			FİYAT PRICE
		Genişlik Width	Derinlik Depth	Yükseklik Height	
PHE4301A	E4301A / E4302A	906	900	147	
PHE4301	E4301 / E4302	1016	925	147	
PHE4351A	E4351A / E4352A E4351AS / E4352AS	1006	1000	147	
PHE4351	E4351 / E4352	1116	1025	147	
PHE6301DA	E6301DA / E6302DA	906	1210	147	
PHE6301D	E6301D / E6302D	1016	1235	147	
PHE6351DA	E6351DA / E6352DA	1006	1360	147	
PHE6351D	E6351D / E6352D	1116	1385	147	
PHE6301WA	E6301WA / E6302WA	1216	900	147	
PHE6301W	E6301W / E6302W	1326	925	147	
PHE6351WA	E6351WA / E6352WA	1366	1000	147	
PHE6351W	E6351W / E6352W	1476	1025	147	
PHE9351A	E9351A / E9352A E9351 / E9352	1428	1435	147	
PHE4301AB	E4301AB / E4302AB	906	935	147	
PHE4331AB	E4331AB / E4332AB	966	995	147	
PHE6301WAB	E6301WAB / E6302WAB	1216	935	147	

PIZZA FIRINI DAVLUMBAZI, MOTORLU
HOOD FOR PIZZA OVEN, WITH MOTOR

ÜRÜN KODU PRODUCT CODE	PIZZA FIRINI KODU PIZZA OVEN CODE	MOTORLU DAVLUMBAZ ÖLÇÜLERİ HOOD WITH MOTOR DIMENSIONS (mm)			FİYAT PRICE
		Genişlik Width	Derinlik Depth	Yükseklik Height	
PHME4301A	E4301A / E4302A	906	1115	360	
PHME4301	E4301 / E4302	1016	1140	360	
PHME4351A	E4351A / E4352A E4351AS / E4352AS	1006	1215	360	
PHME4351	E4351 / E4352	1116	1240	360	
PHME6301DA	E6301DA / E6302DA	906	1425	360	
PHME6301D	E6301D / E6302D	1016	1450	360	
PHME6351DA	E6351DA / E6352DA	1006	1575	360	
PHME6351D	E6351D / E6352D	1116	1600	360	
PHME6301WA	E6301WA / E6302WA	1216	1115	360	
PHME6301W	E6301W / E6302W	1326	1140	360	
PHME6351WA	E6351WA / E6352WA	1366	1215	360	
PHME6351W	E6351W / E6352W	1476	1240	360	
PHME9351A	E9351A / E9352A E9351 / E9352	1428	1650	360	
PHME4301AB	E4301AB / E4302AB	906	1150	360	
PHME4331AB	E4331AB / E4332AB	966	1210	360	
PHME6301WAB	E6301WAB / E6302WAB	1216	1150	360	

PİLİÇ ÇEVİRME MAKİNELERİ

CHICKEN ROTISSERIE MACHINES

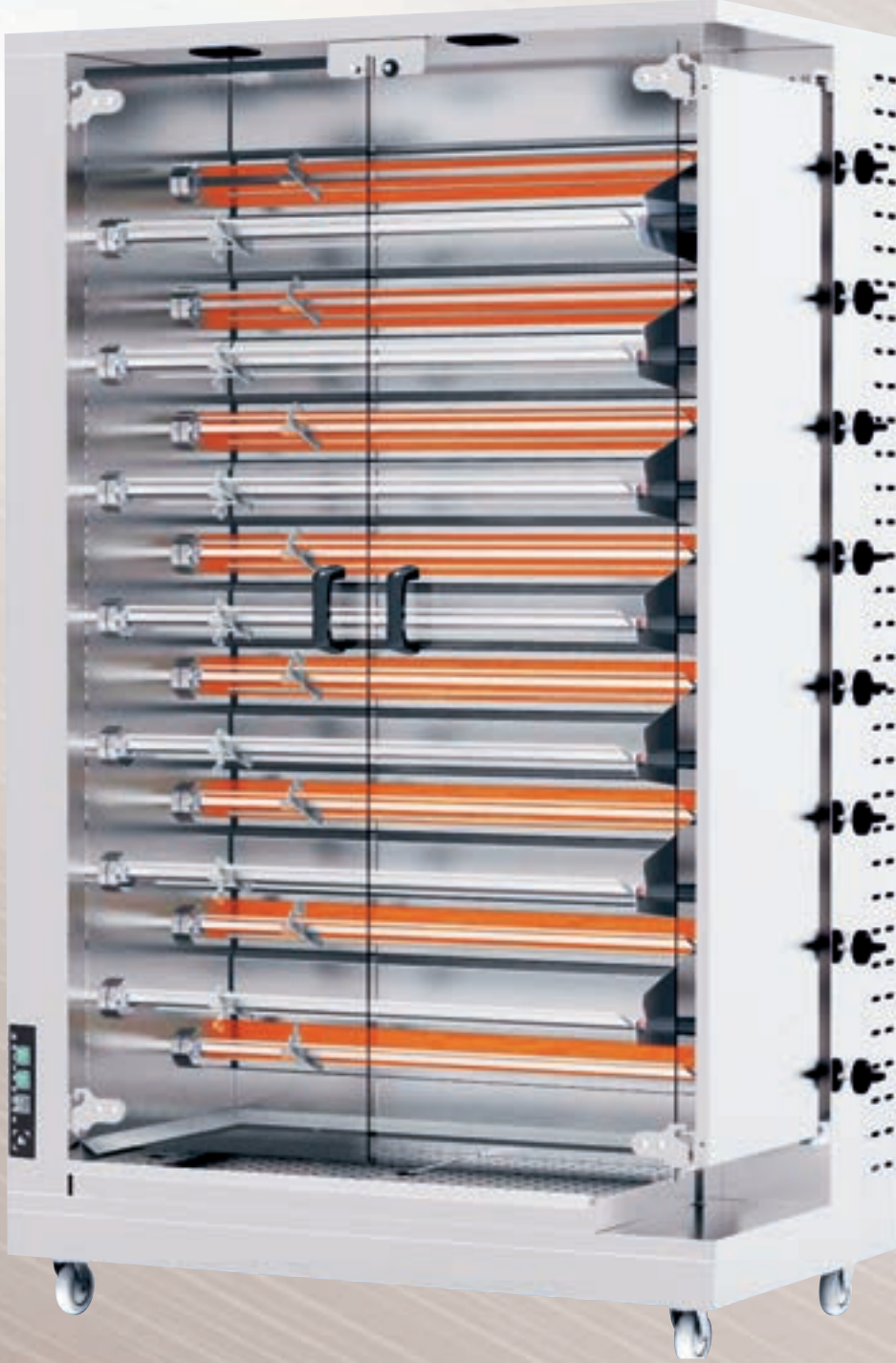

Piliç Çevirme Makinesi, Gazlı / Chicken Rotisserie Machine, Gas

Piliç Çevirme Makinesi, Elektrikli / Chicken Rotisserie Machine, Electrical

Piliç Çevirme Makinesi Aksesuarları / Accessories for Chicken Rotisserie Machine

PİLİÇ ÇEVİRME MAKİNESİ, GAZLI
CHICKEN ROTISSERIE MACHINE, GAS

CRG5

TR

- Her bir radyan ayrı ayrı kontrol edilir
- İç aydınlatma sistemi mevcuttur
- Kapaklarda kullanılan temperli cam ısıya dayanıklıdır
- Şiş ve cam kulpları bakalit ve ısıya dayanıklıdır
- Sessiz çalışma ve kolay kullanım özelliğine sahiptir
- Temizliği ve bakımı kolaydır

EN

- Each burner is controlled individually
- Interior lightening system is available
- Tempered glass used in doors is heat-resisting
- Skewer and glass handles are bakelite and heat-resisting
- Quiet and easy operation
- Easy to clean and maintain



ÜRÜN KODU / PRODUCT CODE	CRG2	CRG3	CRG 4	CRG 5	CRG 6	CRG 7	CRG 8
Şiş / Spit	2	3	4	5	6	7	8
Kapasite / Capacity	8-10 piliç / chickens	12-15 piliç/chickens	16-20 piliç/chickens	20-25 piliç / chickens	24-30 piliç / chickens	28-35 piliç / chickens	32-40 piliç / chickens
Tüketim / Consumption	0,98 m ³ /h	1,46 m ³ /h	1,96 m ³ /h	2,44 m ³ /h	2,94 m ³ /h	3,42 m ³ /h	3,92 m ³ /h
Güç / Power	9,40 kW	14,10 kW	18,80 kW	23,50 kW	28,20 kW	32,90 kW	37,60 kW
Ağırlık / Weight	70 kg	85 kg	110 kg	150 kg	170 kg	190 kg	210 kg
Genişlik / Width	1150 mm	1150 mm	1150 mm	1150 mm	1150 mm	1150 mm	1150 mm
Derinlik / Depth	550 mm	550 mm	550 mm	550 mm	550 mm	550 mm	550 mm
Yükseklik / Height	610 mm	800 mm	980 mm	1330 mm	1520 mm	1720 mm	1908 mm
Fiyat / Price							

**PİLİÇ ÇEVİRME MAKİNESİ, GAZLI
CHICKEN ROTISSERIE MACHINE, GAS****CRG8-15****TR**

- Bekletme ünitesi sayesinde piliçler tazeliğini ve sıcaklığını korur.

EN

- Chickens stay fresh and warm with holding unit of chicken rotisserie machine.

ÜRÜN KODU PRODUCT CODE	CRG8-15
Şiş / Spit	15
Kapasite / Capacity	32-40 piliç / chickens
Tüketim / Consumption	3,92 m ³ /h
Güç / Power	37,60 kW
Ağırlık / Weight	275 kg
Genişlik / Width	1300 mm
Derinlik / Depth	700 mm
Yükseklik / Height	2120 mm
Fiyat / Price	

PİLİÇ ÇEVİRME MAKİNESİ, GAZLI
CHICKEN ROTISSERIE MACHINE, GAS

CRG5C-9



TR

- Bekletme ünitesi sayesinde piliçler tazeliğini ve sıcaklığını korur.

EN

- Chickens stay fresh and warm with holding unit of chicken rotisserie machine.

ÜRÜN KODU / PRODUCT CODE	CRG3C-5	CRG4C-7	CRG5C-9	CRG6C-11
Şiş / Spit	3+2	4+3	5+4	6+5
Kapasite / Capacity	12-15 piliç / chickens	16-20 piliç/chickens	20-25 piliç/chickens	24-30 piliç / chickens
Tüketim / Consumption	1,46 m ³ /h	1,96 m ³ /h	2,44 m ³ /h	2,94 m ³ /h
Güç / Power	14,10 kW	18,40 kW	23,50 kW	28,20 kW
Ağırlık / Weight	105 kg	140 kg	180 kg	200 kg
Genişlik / Width	1300 mm	1300 mm	1300 mm	1300 mm
Derinlik / Depth	700 mm	700 mm	700 mm	700 mm
Yükseklik / Height	1100 mm	1300 mm	1480 mm	2020 mm
Fiyat / Price				

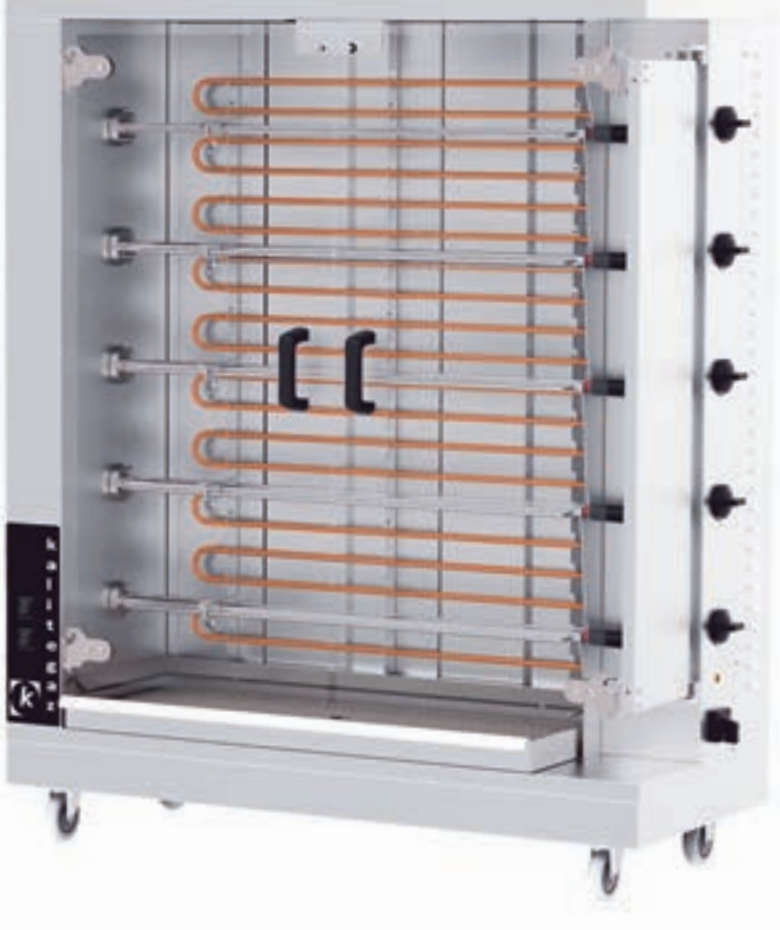
**PİLİÇ ÇEVİRME MAKİNESİ, ELEKTRİKLİ
CHICKEN ROTISSERIE MACHINE, ELECTRICAL****CRE5****TR**

- Her bir rezistans ayrı ayrı kontrol edilir
- İç aydınlatma sistemi mevcuttur
- Kapaklarda kullanılan temperli cam ısıya dayanıklıdır
- Şiş ve cam kulpları bakalit ve ısıya dayanıklıdır
- Sessiz çalışma ve kolay kullanım özelliğine sahiptir
- Temizliği ve bakımı kolaydır

EN

- Each resistance is controlled separately
- Equipped with interior lightening system
- Tempered glass used in doors is heat-resisting
- Skewer and glass handles are bakalite and heat-resisting
- Quiet and easy operation
- Easy to clean and maintain

ÜRÜN KODU / PRODUCT CODE	CRE 2	CRE 3	CRE 4	CRE 5	CRE 6
Şiş / Spit	2	3	4	5	6
Kapasite / Capacity	8-10 piliç/chickens	12-15 piliç/chickens	16-20 piliç/chickens	20-25 piliç/chickens	24-30 piliç/chickens
Güç / Power	6,00 kW	9,00 kW	12,00 kW	15,00 kW	18,00 kW
Gerilim / Voltage	400 V / 50 Hz	400 V / 50 Hz	400 V / 50 Hz	400 V / 50 Hz	400 V / 50 Hz
Ağırlık / Weight	60 kg	80 kg	95 kg	135 kg	155 kg
Genişlik / Width	1150 mm	1150 mm	1150 mm	1150 mm	1150 mm
Derinlik / Depth	550 mm	550 mm	550 mm	550 mm	550 mm
Yükseklik / Height	610 mm	800 mm	980 mm	1330 mm	1520 mm
Fiyat / Price					

**PİLİÇ ÇEVİRME MAKİNESİ AKSESUARLARI
ACCESSORIES FOR CHICKEN ROTISSERIE MACHINE**

CRD



CRM



1110500600



CRB



1110500620



ÜRÜN KODU PRODUCT CODE	STOK KODU STOCK CODE	UYUMLU OLDUĞU ÜRÜNLER COMPATIBLE PRODUCTS	ÜRÜN ADI PRODUCT NAME	ÜRÜN ÖLÇÜSÜ (G x D x Y) PRODUCT DIMENSION (W x D x H)	FİYAT PRICE
CRD	1201400010	CRG2, CRG3, CRG4, CRG5, CRG6, CRG7, CRG8, CRE2, CRE3, CRE4, CRE5, CRE6	Davlumbaz Hood	1145 x 515 x 168 mm	
CRD	1201400011	CRG8-15	Davlumbaz Hood	1145 x 695 x 220 mm	
CRD	1201400012	CRG6C-11	Davlumbaz Hood	1248 x 520 x 290 mm	
CRB	1201000010	CRG2, CRG3, CRG4, CRG5, CRG6, CRG7, CRG8, CRE2, CRE3, CRE4, CRE5, CRE6	Baza, Base	1100 x 470 x 165 mm	
CRB	1201000011	CRG8-15	Baza, Base	1100 x 650 x 165 mm	
CRB	1201000012	CRG6C-11	Baza, Base	1217 x 530 x 300 mm	
CRM	1201000015	CRG2, CRG3, CRG4, CRG5, CRG6, CRG7, CRG8, CRE2, CRE3, CRE4, CRE5, CRE6	Dolap, Cabinet	1100 x 470 x 540 mm	
CRM	1201000020	CRG2, CRG3, CRG4, CRG5, CRG6, CRG7, CRG8, CRE2, CRE3, CRE4, CRE5, CRE6	Dolap, Cabinet	1100 x 470 x 740 mm	
CRM	1201000021	CRG6C-11	Dolap, Cabinet	1220 x 530 x 815 mm	
1110500600	1110500600	CRG2, CRG3, CRG4, CRG5, CRG6, CRG7, CRG8, CRE2, CRE3, CRE4, CRE5, CRE6	But Kafesi Gigot Basket	950 x 130 x 85 mm	
1110500620	1110500620	CRG2, CRG3, CRG4, CRG5, CRG6, CRG7, CRG8, CRE2, CRE3, CRE4, CRE5, CRE6	Kanat Kafesi Wing Basket	950 x 130 x 45 mm	

KIZARMIŞ PİLİÇ EKİPMANLARI

FRIED CHICKEN EQUIPMENTS



Piliç Nemlendirmeli Isıtıcı, Set Üstü / Chicken Humidified Warmer, Countertop
Paneleme Makinesi / Breeding Machine

**PİLİÇ NEMLENDİRMELİ ISITICI, SET ÜSTÜ
CHICKEN HUMIDIFIED WARMER, COUNTERTOP**

TR

- Alt ve üst katları ayrı ayrı termostatik kontrol etme imkanı sağlar.
- Otomatik su doldurma sistemi ile gün boyu nemlendirilerek ürün bekletme imkanı sağlar.
- İç aydınlatması vardır.
- Sıcaklık aralığı 30C / 90C dir.
- Çift taraflı pencere sistemi ile kullanım kolaylığı sunar.

EN

- It provides the opportunity to control the temperature of the lower and upper floors separately,
- Thanks to auto water refill system you don't have to worry water level,
- Interior Lighting System,
- The temperature range 30C-90C (86F-194F)
- It offers ease of use with its double-sided window system.



CHWC3



CHWC5

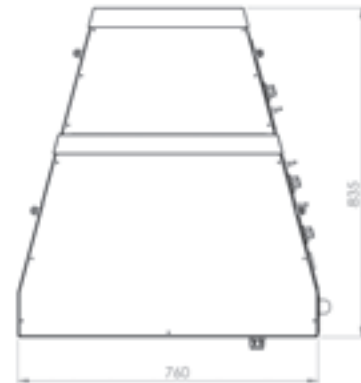
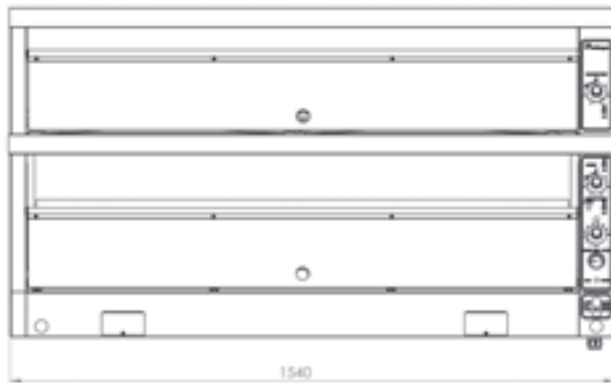

PRODUCT CODE ÜRÜN KODU	PRODUCT NAME ÜRÜN ADI	Dimension (W x D x H) Ürün Ölçüsü(G x D x Y)	Voltage Gerilim	Temperature Sıcaklık	Power Güç	Net Weight Net Ağırlık	Price Fiyat
CHWC3	Piliç Nemlendirmeli Isıtıcı, Set Üstü Chicken Humidified Warmer, Countertop	1540 x 760 x 515 mm	220 V / 50 Hz	30 °C - 85 °C	4kW	130 kg	
CHWC5	Piliç Nemlendirmeli Isıtıcı, Set Üstü Chicken Humidified Warmer, Countertop	1540 x 760 x 835 mm	220 V / 50 Hz	30 °C - 85 °C	5kW	170 kg	
CHWC8	Piliç Nemlendirmeli Isıtıcı, Set Üstü Chicken Humidified Warmer, Countertop	2435 x 760 x 835 mm	220 V / 50 Hz	30 °C - 85 °C	9,5kW	250 kg	

**PİLİÇ PANELEME ÜNİTESİ
BREADING MACHINE****CBU****TR**

- Paslanmaz çelik gövde
- Paslanmaz 1/1 küveti hijyenik ve pratiktir. Temizliği kolaydır.
- Paneleme harcına batırılmasından oluşan un topaklarının fırça vasıtası ile elenerek unun temizlenmesi ve topakların kolayca ayrıştırılmasını sağlar.
- Ergonomik yapısı ve tekerlekli gövdesi sayesinde kullanım kolaylığı sağlar.
- Güçlü motoru ve helezon fırçası ile topak halindeki unu hızlıca tahliye eder ve kullanılabilir temiz unu alt haznesinde biriktirir.

EN

- Stainless Steel Body.
- Hygienic and Practical with Stainless Steel G 1/1 tub. Easy to clean,
- Flour lumps formed are separated from flour by means of a brush. Flour stays clean.
- Provides ease of use thanks to its ergonomic structure and wheeled body,
- With its powerful motor and spiral brush, it quickly evacuates the flour in lump form and collects the clean flour that can be used in its lower chamber.

PRODUCT CODE ÜRÜN KODU	PRODUCT NAME ÜRÜN ADI	Dimension (W x D x H) Ürün Ölçüsü (G x D x Y)	Voltage Gerilim	Net Weight Net Ağırlık	Price Fiyat
CBU	Piliç Paneleme Ünitesi Breeding Machine	1130 x 760 x 850 mm	220 V / 50 Hz	50 kg	

SERVİS ÜNİTELERİ

SERVICE UNITS



Sıcak Servis Üniteleri, Benmari / Hot Service Units, Bain-Marie
Sıcak Servis Üniteleri, Benmari, Dekorlu / Hot Service Units, Bain-Marie, Decor
Soğuk Servis Üniteleri / Cold Service Units
Soğuk Servis Üniteleri, Dekorlu / Cold Service Units, Decor
Nötr Servis Ünitesi / Neutral Service Unit
Nötr Servis Ünitesi, Dekorlu / Neutral Service Unit, Decor

SICAK SERVİS ÜNİTELERİ, BENMARI
HOT SERVICE UNITS, BAIN-MARIE**HSU191****TR**

- Paslanmaz çelik iç ve dış gövde.
- Poliüertan İzolasyon.
- Benmari üst bölüm.
- Sürgülü Pleksiglas arka cam.
- Temperli ön cam.
- Tehşir alanı içi aydınlatma.
- Dijital kumanda paneli.

EN

- Stainless steel inside and outside body.
- Polurethane isolation.
- Bain-marie top.
- Sliding plexiglass rear glass.
- Tempered front glass.
- Inside lighting.
- Digital control panel.

PRODUCT CODE ÜRÜN KODU	PRODUCT NAME ÜRÜN ADI	Dimension (W x D x H) Ürün Ölçüsü (G x D x Y)	Voltage Gerilim	Temperature Sıcaklık	Capacity Kapasite	Power Güç	Net Weight Net Ağırlık	Price Fiyat
HSUB1270	Sıcak Servis Ünitesi, Benmari Hot Service Unit, Bain-Marie	1200 x 700 x 1350 mm	230 V	+40 / +90	3 x Gn 1/1 100	2 kW	85 kg	
HSUB1570	Sıcak Servis Ünitesi, Benmari Hot Service Unit, Bain-Marie	1500 x 700 x 1350 mm	230 V	+40 / +90	4 x Gn 1/1 100	2 kW	100 kg	
HSUB1870	Sıcak Servis Ünitesi, Benmari Hot Service Unit, Bain-Marie	1800 x 700 x 1350 mm	230 V	+40 / +90	5 x Gn 1/1 100	2 kW	114 kg	
HSU110	Sıcak Servis Ünitesi, Benmari Hot Service Unit, Bain-Marie	1105 x 800 x 1350 mm	230 V	+40 / +90	3 x Gn 1/1 100	1 kW	170 kg	
HSU143	Sıcak Servis Ünitesi, Benmari Hot Service Unit, Bain-Marie	1430 x 800 x 1350 mm	230 V	+40 / +90	4 x Gn 1/1 100	1 kW	180 kg	
HSU191	Sıcak Servis Ünitesi, Benmari Hot Service Unit, Bain-Marie	1910 x 800 x 1350 mm	230 V	+40 / +90	5 x Gn 1/1 100	1 kW	220 kg	

SICAK SERVİS ÜNİTELERİ, BENMARI, DEKORLU
HOT SERVICE UNITS, BAIN-MARIE, DECOR

⚡ HSUBD200

Ceviz
Walnut

- Bu görselde ceviz rengi dekor kullanılmıştır.
- Walnut decor is used in this image.

TR

- Paslanmaz çelik iç ve dış gövde.
- Poliüertan İzolason.
- Benmari üst bölüm.
- Sürgülü Pleksiglas arka cam.
- Temperli ön cam.
- Tehşir alanı içi aydınlatma.
- Dijital kumanda paneli.
- Dekoratif ahşap kaplama.
- Granit çalışma tezgahı.

EN

- Stainless steel inside and outside body.
- Polurethane isolation.
- Bain-marie top.
- Sliding plexiglass rear glass.
- Tempered front glass.
- Inside lighting.
- Digital control panel.
- Decorative wood cover.
- Granite worktop.

KAPLAMA RENK OPSİYONLARI
COVER COLOUR OPTIONS

PRODUCT CODE ÜRÜN KODU	PRODUCT NAME ÜRÜN ADI	Dimension (W x D x H) Ürün Ölçüsü (G x D x Y)	Voltage Gerilim	Temperature Sıcaklık	Capacity Kapasite	Power Güç	Net Weight Net Ağırlık	Price Fiyat
HSUBD118	Sıcak Servis Ünitesi, Benmari, Dekorlu Hot Service Unit, Bain-Marie, with Decor	1095 x 880 x 1350 mm	230 V	+40 / +90	3 x Gn 1/1 100	1 kW	170 kg	
HSUBD150	Sıcak Servis Ünitesi, Benmari, Dekorlu Hot Service Unit, Bain-Marie, with Decor	1415 x 880 x 1350 mm	230 V	+40 / +90	4 x Gn 1/1 100	1 kW	180 kg	
HSUBD200	Sıcak Servis Ünitesi, Benmari, Dekorlu Hot Service Unit, Bain-Marie, with Decor	1915 x 880 x 1350 mm	230 V	+40 / +90	5 x Gn 1/1 100	1 kW	220 kg	

SOĞUK SERVİS ÜNİTELERİ
COLD SERVICE UNITS**CSU191****TR**

- Paslanmaz çelik iç ve dış gövde.
- Poliüertan İzolasyon.
- 35 / 40 / m³ çevre dostu HCFC free dolap.
- Sürgülü Pleksiglas arka cam.
- Temperli ön cam.
- Tehşir alanı içi aydınlatma.
- Dijital Kumanda Paneli.

EN

- Stainless steel inside and outside body.
- Polurethane isolation.
- 35 / 40 / m³ ecology friendly HCFC free cooler.
- Sliding plexiglass rear glass.
- Tempered front glass.
- Inside lighting.
- Digital control panel.

PRODUCT CODE ÜRÜN KODU	PRODUCT NAME ÜRÜN ADI	Dimension (W x D x H) Ürün Ölçüsü (G x D x Y)	Voltage Gerilim	Temperature Sıcaklık	Capacity Kapasite	Power Güç	Net Weight Net Ağırlık	Price Fiyat
CSU110	Soğuk Servis Ünitesi Cold Service Unit	1105x 800 x 1350 mm	230 V	-2 / +8	3 x Gn 1/1 100	0,35 kW	170 kg	
CSU143	Soğuk Servis Ünitesi Cold Service Unit	1430 x 800 x 1350 mm	230 V	-2 / +8	4 x Gn 1/1 100	0,38 kW	180 kg	
CSU191	Soğuk Servis Ünitesi Cold Service Unit	1910 x 800 x 1350 mm	230 V	-2 / +8	5 x Gn 1/1 100	0,47 kW	220 kg	
CSU240	Soğuk Servis Ünitesi Cold Service Unit	2400 x 800 x 1350 mm	230 V	-2 / +8	6 x Gn 1/1 100	0,55 kW	250 kg	

SOĞUK SERVİS ÜNİTELERİ, DEKORLU
COLD SERVICE UNITS, DECOR

CSUD200

Ceviz
Walnut

- Bu görselde ceviz rengi dekor kullanılmıştır.
- Walnut decor is used in this image.

TR

- Paslanmaz çelik iç ve dış gövde.
- Poliüertan İzolasyon.
- 35 / 40 / m³ çevre dostu HCFC free dolap.
- Sürgülü Pleksiglas arka cam.
- Temperli ön cam.
- Tehşir alanı içi aydınlatma.
- Dijital kumanda paneli.
- Dekoratif ahşap kaplama.
- Granit çalışma tezgahı.

EN

- Stainless steel inside and outside body.
- Polurethane isolation.
- 35 / 40 / m³ eceology friendly HCFC free cooler.
- Sliding plexiglass rear glass.
- Tempered front glass.
- Inside lighting.
- Digital control panel.
- Decorative wood cover.
- Granite worktop.

KAPLAMA RENK OPSİYONLARI
COVER COLOUR OPTIONS

PRODUCT CODE ÜRÜN KODU	PRODUCT NAME ÜRÜN ADI	Dimension (W x D x H) Ürün Ölçüsü (G x D x Y)	Voltage Gerilim	Temperature Sıcaklık	Capacity Kapasite	Power Güç	Net Weight Net Ağırlık	Price Fiyat
CSUD118	Soğuk Servis Ünitesi, Dekorlu Cold Service Unit, with Decor	1095 x 880 x 1350 mm	230V	-2 / +8	3 x Gn 1/1 100	0,35 kW	170 kg	
CSUD150	Soğuk Servis Ünitesi, Dekorlu Cold Service Unit, with Decor	1450 x 880 x 1350 mm	230V	-2 / +8	4 x Gn 1/1 100	0,38 kW	180 kg	
CSUD200	Soğuk Servis Ünitesi, Dekorlu Cold Service Unit, with Decor	1915 x 880 x 1350 mm	230V	-2 / +8	5 x Gn 1/1 100	0,47 kW	220 kg	
CSUD250	Soğuk Servis Ünitesi, Dekorlu Cold Service Unit, with Decor	2415 x 880 x 1350 mm	230V	-2 / +8	6 x Gn 1/1 100	0,55 kW	250 kg	

**NÖTR SERVİS ÜNİTESİ
NEUTRAL SERVICE UNIT****NSU72****TR**

- Paslanmaz çelik iç ve dış gövde.
- Yüksekliği ayarlanabilen paslanmaz ayaklar.
- Dekoratif ahşap kaplama.
- Granit çalışma tezgahı.

EN

- Stainless steel inside and outside body.
- Adjustable, stainless steel legs.
- Decorative wood cover.
- Granite worktop.

NSUD80**KAPLAMA RENK OPSİYONLARI
COVER COLOUR OPTIONS****Zigana Meşe**
zigana oak**Yeni Meşe**
new oak**Ladin Spruce**
Ladin spruce**Kırmızı**
Red**Ceviz**
Walnut**Arusha Wenge**
Arusha Wenge**Ceviz**
Walnut

- Bu görselde ceviz rengi dekor kullanılmıştır.
- Walnut decor is used in this image.

PRODUCT CODE ÜRÜN KODU	PRODUCT NAME ÜRÜN ADI	Dimension (W x D x H) Ürün Ölçüsü (G x D x Y)	Net Weight Net Ağırlık	Price Fiyat
NSU72	Nötr Servis Ünitesi Neutral Service Unit	800 x 800 x 850 mm	40 kg	
NSUD80	Nötr Servis Ünitesi, Dekorlu Neutral Service Unit, with Decor	800 x 880 x 870 mm	40 kg	

SALAMANDER

SALAMANDER



Chef Grill

Pita Fırını (Salamander), Gazlı / Pita Oven (Salamander), Gas
Pita Fırını (Salamander), Elektrikli / Pita Oven (Salamander), Electrical
Salamander, Elektrikli / Salamander, Electrical

CHEF GRILL**CG6241**

VIDEO

**TR**

- Isıtıcı yüzeyi kısa bir süre içerisinde 700-800 °C ulaşır ve bu sayede çok hızlı pişirme özelliğine sahiptir
- Radyan alevinin kontrol dışı sönmeye durumunda gazı otomatik olarak kesecek emniyet ventili (termokulp) tertibatı vardır
- Radyanlar üst kısımda olup üstten ısıtılmalıdır
- İki kademeli sıcaklık ayarı vardır
- Izgara ve tepsisi yan taraftaki mekanizma sayesinde ısıtıcılara kolaylıkla yaklaştırılıp uzaklaştırılabilir
- Izgara ve tepsisi yiyeceklerin kolaylıkla yerleştirilip alınabilmesi için öne ve arkaya hareket eder
- Izgaranın altında bulunan su tepsisi sayesinde yağlar donmaz ve parlamaya neden olmaz.
- Su tepsisi sayesinde yiyecekler hep yumuşak kalır

EN

- Burner surface reaches 700-800 °C in a short time. So, it has very fast cooking feature
- Equipped with thermocouples for cutting gas supply in case of any emergency
- Burners are placed on top and heated from above
- There are two different level cooking temperature
- Grill and tray can be easily zoomed in to burners with upward & downward mechanism
- Grill and tray move to back & front for easy food replacement
- Fats don't get solid and don't cause flame through water tray placed under the grill
- Foods are always soft by help of water tray

ÜRÜN KODU PRODUCT CODE	ÜRÜN ADI PRODUCT NAME	ÜRÜN ÖLÇÜSÜ (G x D x Y) Dimension (W x D x H)	Izgara Ölçüsü Grill Dimension	Gaz Sarfiyatı Doğalgaz / Propan Gas Consumption Naturel Gas / Propane	Güç Power	Net Ağırlık Net Weight	Fiyat Price
CG6241	CHEF GRILL	1020 x 560 x 670 mm	620 x 410 mm	1,412 m ³ /h / 0,416 kg/h	17,2 kW	75 kg	

PİTA FIRINI (SALAMANDER), GAZLI
PİTA OVEN (SALAMANDER), GAS

KLG302



KLG304



KLG303



KLG306



TR

- Radyan alevinin kontrol dışı sönmesi durumunda gazı otomatik olarak kesecek emniyet ventili (Termokulp) tertibatı vardır
- Isıtıcı radyanlar üst kısımda olup üstten ısıtılmalıdır
- Radyanların normal ve kısık ateş olarak ısısı ayarlanabilir
- Izgara ve tepsisi yan taraftaki mekanizma sayesinde ısıtıcı rezistanslara kolaylıkla yakınlaştırılıp uzaklaştırılabilir
- Izgara ve tepsisi ısıtılacak yiyeceklerin kolaylıkla yerleştirilip alınabilmesini sağlayacak şekilde öne doğru kızaktır.

EN

- Equipped with thermocouples for cutting gas supply in case of any emergency
- Heated from above as heating radiants placed on top
- Heat of the radiants adjustable as low and normal heat
- Grill and tray adjustable upwards&downwards
- Grill and tray adjustable back to front for easy removal of heated food

ÜRÜN KODU / PRODUCT CODE	KLG302	KLG303	KLG304	KLG306
Radyan / Burner	2	3	4	6
Ürün Ölçüsü (G x D x Y) / Product Dimension (W x D x H)	650 x 480 x 560 mm	810 x 480 x 560 mm	970 x 480 x 560 mm	1290 x 480 x 560 mm
Izgara Ölçüsü / Grill Dimension	350 x 360 mm	500 x 360 mm	650 x 360 mm	950 x 360 mm
Net Ağırlık / Net Weight	39 kg	43 kg	47 kg	55 kg
Güç / Power	6,62 kW	9,94 kW	13,25 kW	19,88 kW
Tüketim / Consumption	0,68 m ³ /h	1,02 m ³ /h	1,35 m ³ /h	2,03 m ³ /h
Fiyat / Price				

**PİTA FIRINI (SALAMANDER), ELEKTRİKLİ
PITA OVEN (SALAMANDER), ELECTRICAL****KLK 303-E****TR**

- Isıtıcı rezistanslar üst kısımda olup üstten ısıtılmalıdır
- Isıtıcı rezistansların ısısı ayarlanabilir
- Izgara ve tepsisi yan taraftaki mekanizma sayesinde ısıtıcı rezistanslara kolaylıkla yakınlaştırılıp uzaklaştırılabilir
- Izgara ve tepsisi ısıtılacak yiyeceklerin kolaylıkla yerleştirilip alınabilmesini sağlayacak şekilde öne doğru kızaklıdır

EN

- Heated from above as heating resistances placed on top
- Heat of the resistance adjustable
- Grill and tray adjustable upwards & downwards
- Grill and tray adjustable back to front for easy removal of heated food

**KLK 305-E**

ÜRÜN KODU / PRODUCT CODE	KLK 303-E	KLK 305-E
Ürün Ölçüsü (G x D x Y) / Product Dimension (W x D x H)	970 x 550 x 560 mm	1290 x 550 x 560 mm
Izgara Ölçüsü / Grill Dimension	650 x 360 mm	950 x 360 mm
Net Ağırlık / Net Weight	47 kg	55 kg
Güç / Power	6,00 kW	10,00 kW
Tüketim / Consumption	400 V / 50 Hz	400 V / 50 Hz
Fiyat / Price		

SALAMANDER, ELEKTRİKLİ
SALAMANDER, ELECTRICAL

TR

- Paslanmaz çelik gövdeli Hijyenik bir üründür
- Yukarı ve aşağı yönde ayarlanabilir hareketli ısıtıcı
- Ayarlanabilir tepsi ve ızgara

EN

- Hygienic product with its stainless steel body
- Height adjustable heating element
- With drip collecting tray and grid



KLG 300-45



KLG 300-60



ÜRÜN KODU / PRODUCT CODE	KLG 300-45	KLG 300-60
Genişlik / Width	450 mm	600 mm
Derinlik / Depth	535 mm	535 mm
Yükseklik / Height	535 mm	535 mm
Ağırlık / Weight	33 kg	39 kg
Gerilim / Voltage	230 V / 50 Hz	230 V / 50 Hz
Güç / Power	3,00 kW	3,00 kW
Fiyat / Price		

KAFETERYA

CAFE



Tost Makinesi / Contact Grill

Konveyörlü Ekmek Kızartma Makinesi / Conveyor Toaster

Sos Benmari / Round Pot Bain Marie

Kapaklı Patates Dinlendirme Ünitesi / Countertop Electric Chip Scuttle

Yağ Ayırıştırıcı / Grease Separator

TEK KAPAKLI TOST MAKİNESİ
SINGLE COVER CONTACT GRILL

RN101A



RN101B



RN101C

**TR**

- Paslanmaz çelik gövdeli, hijyenik, ızgara olarak da kullanılabilen çok amaçlı ürünlerdir

EN

- It is a hygienic product with its stainless steel body and multipurpose products that can also be used as grill

ÜRÜN KODU / PRODUCT CODE	RN101A / B / C
Genişlik / Width	410 mm
Derinlik / Depth	410 mm
Yükseklik / Height	205 mm
Döküm Genişlik / Plate Width	380 mm
Döküm Derinlik / Plate Depth	280 mm
Ağırlık / Weight	29 kg
Gerilim / Voltage	230 V / 50 Hz
Güç / Power	2,25 kW
Fiyat / Price	

BLOK KAPAKLI TOST MAKİNESİ
BLOCK COVER CONTACT GRILL**TR**

- Paslanmaz çelik gövdeli, hijyenik, ızgara olarak da kullanılabilen çok amaçlı ürünlerdir

EN

- It is a hygienic product with its stainless steel body and multipurpose products that can also be used as grill



ÜRÜN KODU / PRODUCT CODE	RN102
Genişlik / Width	545 mm
Derinlik / Depth	410 mm
Yükseklik / Height	205 mm
Döküm Genişlik / Plate Width	520 mm
Döküm Derinlik / Plate Depth	280 mm
Ağırlık / Weight	36 kg
Gerilim / Voltage	230 V / 50 Hz
Güç / Power	2,50 kW
Fiyat / Price	

ÇİFT KAPAKLI TOST MAKİNESİ
DOUBLE COVER CONTACT GRILL

RN103A



RN103B



TR

- Paslanmaz çelik gövdeli, hijyenik, ızgara olarak da kullanılabilen çok amaçlı ürünlerdir

EN

- It is a hygienic product with its stainless steel body and multipurpose products that can also be used as grill



ÜRÜN KODU / PRODUCT CODE	RN103A/B
Genişlik / Width	545 mm
Derinlik / Depth	410 mm
Yükseklik / Height	205 mm
Alt Döküm Genişlik / Bottom Plate Width	520 mm
Alt Döküm Derinlik / Bottom Plate Depth	280 mm
Üst Döküm Genişlik / Top Plate Width	220+220 mm
Üst Döküm Derinlik / Top Plate Depth	260 mm
Ağırlık / Weight	37 kg
Gerilim / Voltage	230 V / 50 Hz
Güç / Power	3,20 kW
Fiyat / Price	

**KONVEYÖRLÜ EKMEK KIZARTMA MAKİNESİ
CONVEYOR TOASTER****RN125****TR**

- Paslanmaz çelik gövdeli hijyenik bir üründür.
- Ürün düşük, orta ve yüksek derecede kızartma yapabilecek şekilde tasarlanmıştır.
- Motor ve elektrik aksamını yüksek ısıdan korumak için soğutucu fan ile desteklenmiştir.

EN

- It is a hygienic product with its stainless steel body.
- The product is appropriate for toasting in low, medium and high degrees.
- It has a cooling mechanism to protect the motor and other electrical components from high heat.

ÜRÜN KODU / PRODUCT CODE	RN 125
Genişlik / Width	460 mm
Derinlik / Depth	600 mm
Yükseklik / Height	410 mm
Ağırlık / Weight	25 kg
Gerilim / Voltage	230 V / 50 Hz
Güç / Power	3,85 kW
Kapasite / Capacity	500 dilim / slice
Fiyat / Price	

BENMARİ SULU, YUVARLAK KAP BAIN-MARIE VAPOUR, ROUND POT

TR

- Paslanmaz çelik gövde
- Homojen ısı dağılımı sayesinde tüm küvetlerde eşit sıcaklık ile muhafaza edilir.
- Gövdesi içinde muhafaza edilen su emniyetli vana sistemi sayesinde kolayca tahliye edilir.
- 110 C güvenlik termostatu kullanılmaktadır.
- 30 C - 79 C termostat kullanılmaktadır.

EN

- Stainless Steel Body,
- Provides equal heat level for each tub and keeps the sauce/soup same level heat thanks to homogeneous heat distribution.
- Easy to discharge the water inside of the tank with water valve,
- 30 C - 79 C thermostat,
- 110 C limit thermostat for safety.

BMV6

PRODUCT CODE ÜRÜN KODU	PRODUCT NAME ÜRÜN ADI	Dimension (W x D x H) Ürün Ölçüsü (G x D x Y)	Voltage Gerilim	Net Weight Net Ağırlık	Price Fiyat
BMV2	Benmari Sulu, 2 Yuvarlak Kap Bain-Marie Vapour, 2 Round Pots	3000 x 600 x 270 mm	220 V / 50 Hz	9 kg	
BMV4	Benmari Sulu, 4 Yuvarlak Kap Bain-Marie Vapour, 4 Round Pots	450 x 600 x 270 mm	220 V / 50 Hz	12 kg	
BMV6	Benmari Sulu, 6 Yuvarlak Kap Bain-Marie Vapour, 6 Round Pots	750 x 600 x 270 mm	220 V / 50 Hz	15 kg	

PATATES DİNLENDİRME, KATLANIR KAPAKLI CHIPS SCUTTLE, FOLDING LID

TR

- Paslanmaz çelik gövde
- Enerji regülatörü ile kolay kontrol sağlar.
- Kolay açılıp kapatılabilir kapağı sayesinde ısı kaybı minimum seviyeye indirilir.
- Gövdesinde yer alan tepsisi sayesinde hazne içinde biriken tortu ve kırıntılar kolayca çıkartılıp temizlenebilir.

EN

- High grade stainless steel,
- Folding hinged lid,
- Removable drain plate,
- Perforated base - helps the oil or fat drain.

CSFL4550E

PRODUCT CODE ÜRÜN KODU	PRODUCT NAME ÜRÜN ADI	Dimension (W x D x H) Ürün Ölçüsü(G x D x Y)	Voltage Gerilim	Net Weight Net Ağırlık	Price Fiyat
CSFL4550E	Patates Dinlendirme, Katlanır Kapaklı Chips Scuttle, Folding Lid	450 x 500 x 460 mm	220 V / 50 Hz	12 kg	

**YAĞ AYRIŞTIRICI
GREASE SEPARATOR****OS30****TR**

- Paslanmaz çelik gövdeli hijyenik bir üründür.
- Atık yağları süzerek, atık su ve yağı ayırır.
- Yağ kokusunun oluşmasını engeller.

EN

- Stainless steel, hygienic body.
- Separates water and grease.
- Prevents grease smell.

ÜRÜN KODU / PRODUCT CODE	OS-20	OS-30	OS-60
Kapasite / Capacity	20 lt	30 lt	60 lt
Genişlik / Width	650 mm	730 mm	900 mm
Derinlik / Depth	340 mm	400 mm	530 mm
Yükseklik / Height	310 mm	405 mm	625 mm
Ağırlık / Weight	17 kg	20 kg	41 kg
Fiyat / Price			



A series of horizontal dotted lines spanning the width of the page, providing a template for writing notes.



NOTLAR / NOTES

A series of horizontal dotted lines for writing notes.



A series of horizontal dotted lines spanning the width of the page, providing a template for writing notes.

NOTLAR / NOTES

A series of horizontal dotted lines for writing notes.

 **kalitegaz**

RINNOVA

RODO



www.facebook.com/KalitegazRinnova



<https://twitter.com/kalitegaz>



www.instagram.com/kalitegaz_rinnova



www.youtube.com/channel/UC9TN4xtYRWtP-3iLiGU29Cw/featured



linkedin.com/company/kalitegaz/about

www.kalitegaz.com



KALİTE ENDÜSTRİYEL MUTFAK EKİPMANLARI SAN. ve TİC. LTD. ŞTİ.

İkitelli Organize Sanayi Bölgesi Atatürk Bulvarı Sürmeli İş Merkezi No: 108/B32 · 34490 Başakşehir - İstanbul / Türkiye

Tel: +90 212 99 34 · Fax: +90 212 671 99 44

www.kalitegaz.com / info@kalitegaz.com